

Energy Environment and Society

Suman Sedhai
Institute of Engineering
Central Campus
Made using L^AT_EX

March 31, 2015

Contents

1	Technology and Development	5
1.1	Introduction to Technology	5
1.2	Appropriate Technology	6
1.3	Technology Transfer	7
1.4	Impact of Technology on Society	8
2	Energy Basics	11
2.1	Energy	11
2.2	Classification of Energy Sources	12
2.3	Importance of Energy in achieving Maslow's hierarchy of Needs	14
2.3.1	Maslow's Hierarchy of Needs or Theory of Human Needs	14
2.4	Human Development Index	15
2.5	Current Energy Trends, Demand and Supply of Energy in World and Nepal	16
2.5.1	Energy Trends, Demand and Supply in World	16
2.5.2	Energy Trends, Demand and Supply in Nepal	17
2.6	Introduction to Global Warming	19
2.6.1	Kyoto Protocol and Clean Development Mechanism	21
2.7	Conventional/Non conventional and Renewable/Non Renewable Energy Sources	22
2.7.1	Conventional/Non conventional Energy Sources	22
2.7.2	Renewable/Non Renewable Energy Sources	23
2.7.3	Nuclear power stations	23
3	Renewable Energy Sources	25
3.1	Solar Energy	25
3.1.1	Some Basic Terms	26
3.1.2	Tracking System	29
3.1.3	Solar Thermal Energy(STE)	30
3.1.4	Solar Thermal Collector	31
3.1.5	Solar Water Heater(SWH)	33
3.1.6	Solar Drier	34
3.1.7	Solar Cooker	35
3.1.8	Solar Thermal Power Plants	35
3.1.9	Solar Photovoltaic(PV) Cells	36
3.2	Hydro Power	37
3.2.1	Classification of Hydropower	38
3.2.2	Water Turbines	39
3.2.3	Importance of Micro Hydro Power Project: Nepal's Context	42
3.3	Wind Energy	43
3.3.1	Wind Generation	43
3.3.2	Advantages of Wind Energy	46
3.3.3	Disadvantages of Wind Energy	46
3.4	Geothermal Energy	47
3.4.1	Geothermal Heat Pumps	47
3.4.2	Advantages and Disadvantages of Geothermal Energy	48
3.4.3	Applications	49
3.4.4	Geothermal Energy in Nepal	50
3.5	Biomass and Bioenergy	50

3.5.1	Types Of Biomass	50
3.5.2	Conversion of Biomass to Biofuel	51
3.5.3	Syngas	56
3.6	Hydrogen Energy	57
3.6.1	Advantages and Disadvantages	59
3.6.2	Applications	59
3.7	Fuel Cells	60
3.7.1	Principle of Operation	60
3.7.2	Types of Fuel Cells	61
3.7.3	Material selection for Fuel Cells	62
4	Environmental Impact of Energy Sources	65
4.1	Emission Hazard	65
4.1.1	Indoor Pollutants	65
4.1.2	Automotive Pollution	66
4.2	Battery Hazards	66
4.2.1	Explosion	66
4.2.2	Explosion	67
4.2.3	Poisoning	67
4.2.4	Toxic Materials	67
4.2.5	Safety Methods	67
4.2.6	Recycling of Batteries	67
4.3	Nuclear Hazard	68
4.3.1	Biological Effect of Radioactive Radiation	68
5	Energy Storage	69
5.1	Hybrid Vehicles	70
5.1.1	Types	71
5.1.2	Advantages and Disadvantages	71
5.2	Smart Grid Systems	72
5.3	Batteries	73
5.3.1	Principle of Operation	73
5.3.2	C Rate	74
5.3.3	Lead Acid Batteries	74
5.3.4	Types	74
5.3.5	Battery Service Types	74
5.3.6	Nickel Batteries	75
5.3.7	Lithium Batteries	76
5.3.8	Lead-Acid Batteries	76
5.3.9	Flow Batteries	77
5.3.10	Metal-Air Batteries	78
5.3.11	Sodium-Sulphur Batteries(NaS)	78
5.4	Super Capacitors	79

Chapter 1

Technology and Development

1.1 Introduction to Technology

The word technology made from Greek words *techne* which means "craft" and *-logy* means "scientific study of". So technology means the "scientific study of craft". Craft in this case, means any method or invention that allow humans to control or adapt to their environment.

- Scientific application of knowledge
- Systematic application of organized knowledge and tangibles(tools and material)

The purposeful application of information in the design, production, and utilization of goods and services, and in the organization of human activities. Technology is generally divided into five categories

1. **Tangible:** blueprints, models, operating manuals, prototypes.
2. **Intangible:** consultancy, problem-solving, and training methods.
3. **High:** entirely or almost entirely automated and intelligent technology that manipulates ever finer matter and ever powerful forces.
4. **Intermediate:** semiautomated partially intelligent technology that manipulates refined matter and medium level forces.
5. **Low:** labor-intensive technology that manipulates only coarse or gross matter and weaker forces

Technology is the practical use of human knowledge to extend human abilities and to satisfy human needs and wants. It involves turning natural items into useful products. The areas of science, technology, and engineering are related but different.

Scientists try to explain how things happen.

Engineers figure out how to make things.

Technologists make things by operating machines and assembling parts.

Technology advances by adapting, so each new product is an improvement over an existing one. New inventions are almost always based on earlier accomplishments.

Technology developed because people had ideas they turned into useful devices. Resources of technology include **people, information, tools and machines, capital, time, materials, and energy**. Companies buy resources needed to create new technology. They hire people with the knowledge and skill to make products.

Three aspects of technology

1. Operations Technology: What task are being performed
2. Material technology: What material and supplies are used
3. Knowledge technology: What do people have to know

1.2 Appropriate Technology

Appropriate technology is an ideological movement (and its manifestations) originally articulated as intermediate technology by the economist Dr. Ernst Friedrich "Fritz" Schumacher in his influential work, *Small is Beautiful*. Though the nuances of appropriate technology vary between fields and applications, it is generally recognized as encompassing technological choice and application that is **small-scale, decentralized, labor-intensive, energy-efficient, environmentally sound, and locally controlled**. Both Schumacher and many modern-day proponents of appropriate technology also emphasize the technology as people-centered.

Appropriate technology is most commonly discussed in its relationship to economic development and as an alternative to transfers of capital-intensive technology from industrialized nations to developing countries. However, appropriate technology movements can be found in both developing and developed countries. In developed countries, the appropriate technology movement grew out of the energy crisis of the 1970s and focuses mainly on environmental and sustainability issues.

Appropriate technology has been used to address issues in a wide range of fields. Well-known examples of appropriate technology applications include: bike- and hand-powered water pumps (and other self-powered equipment), the universal nut sheller, self-contained solar-powered light bulbs and street lights, and passive solar building designs. Today appropriate technology is often developed using open source principles, which have led to open-source appropriate technology (OSAT) and thus many of the plans of the technology can be freely found on the Internet. OSAT has been proposed as a new model of enabling innovation for sustainable development. Dr. Ernst Friedrich "Fritz" Schumacher is credited as the founder of the appropriate technology movement. Schumacher first articulated the idea of "intermediate technology," now known as appropriate technology, in a 1962 report to the Indian Planning Commission in which he described India as long in labor and short in capital, calling for an "intermediate industrial technology" that harnessed India's labor surplus. Schumacher had been developing the idea of intermediate technology for several years prior to the Planning Commission report. In 1955, following a stint as an economic advisor to the government of Burma, he published the short paper "Economics in a Buddhist Country," his first known critique of the effects of Western economics on developing countries. In addition to Buddhism, Schumacher also credited his ideas to Gandhi.

Initially, Schumacher's ideas were rejected by both the Indian government and leading development economists. Spurred to action over concern the idea of intermediate technology would languish, Schumacher, George McRobie, Mansur Hoda and Julia Porter brought together a group of approximately 20 people to form the Intermediate Technology Development Group (ITDG) in May 1965. Schumacher described the concept of appropriate technology to a mass audience in his influential work, *Small is Beautiful: Economics as if People Mattered*.

According to Jequier and Gerard (1993), "Appropriate Technology (AT)" is now recognized as the generic term for a wide range of technologies characterized by following features:

1. low investment cost per work place
2. low capital investment per unit of output
3. organizational simplicity
4. high adaptability to a particular social cultural environment
5. sparing use of natural resources
6. low cost of final product or high potential for employment.

According to Darrow and Rick (1978), appropriate technologies:

1. are low in capital costs
2. use local materials whenever possible
3. create jobs, employing local skills and labor
4. are small enough in scale to be affordable by a small group of farmers
5. can be understood, controlled and maintained by villagers wherever possible, without high level of Western style education

6. can be produced out of a small metal working shop, if not in a village itself
7. suppose that people can and will work together to collectively bring improvements to their communities, recognizing that in most of the world important decisions are made by groups rather than by individuals
8. involve decentralized renewable energy sources, such as wind power, solar energy, water power, mechanic gas, animal power and pedal power (such as in that highly efficient machine, the bicycle)
9. make technology understandable to the people who are using it and thus suggest ideas that could be used in further innovations
10. are flexible so that they can continue to be used or adapted to fit changing circumstances
11. do not involve patents, royalties, consultant fees, import duties, shopping changes; practical plans can be obtained free of cost and no further payment is involved.

Characteristics Importance of Appropriate Technology

Appropriate technology was meant to address four problems: extreme poverty, starvation, unemployment and urban migration. Some characteristics of appropriate technologies are listed below.

1. Suited to the societies being considered
2. Meets the actual need of people
3. Affordable to those people being considered
4. Optimization of local Resources
5. Manufactured and Operated by local labor and expertise
6. Environmentally friendly
7. Using Renewable Energy Sources

1.3 Technology Transfer

Technology transfer, also called transfer of technology (TOT), is the process of transferring skills, knowledge, technologies, methods of manufacturing, samples of manufacturing and facilities among governments or universities and other institutions to ensure that scientific and technological developments are accessible to a wider range of users who can then further develop and exploit the technology into new products, processes, applications, materials or services.

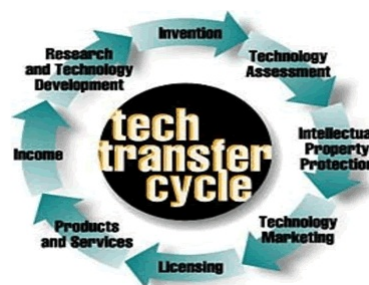

Figure 1.3.1: Process of technology transfer

It is closely related to (and may arguably be considered a subset of) knowledge transfer. **Horizontal transfer** is the movement of technologies from one area to another. At present transfer of technology (TOT) is primarily horizontal. **Vertical transfer** occurs when technologies are moved from applied research centers to research and development departments.

Many companies, universities and governmental organizations now have an Office of Technology Transfer (TTO) dedicated to identifying research which has potential commercial interest and strategies for how to exploit it. The research result may be of scientific and commercial interest.

As a result of the potential complexity of the technology transfer process, technology transfer organizations are often multidisciplinary, including economists, engineers, lawyers, marketers and scientists. The dynamics of the technology transfer process has attracted attention in its own right, and there are several dedicated societies and journals. Technology transfer requires a proactive approach that combines engaging researchers, promoting the technology, and encouraging potential industrial partners to use the technology.

Importance of Technology Transfer

Technology transfer helps develop early stage intellectual property into tools for direct use by the research community, or into bases for new platforms, products, or services to be made into products for public use. Successful collaborations are formed between researchers across different universities or industries in order to advance the knowledge in a particular field or to further develop a technology. These collaborations may result in licensing or sponsored research opportunities that benefit both partners. In addition, technology transfer ensures that the interests and rights of the university in the intellectual property are protected. The university is able to retain the intellectual property rights of the technology and issue a license for the conditional use of the technology.

Successful transfer and development of the technology helps promote the research institution and its commercial partners. The university obtains recognition and increases its reputation for their research and innovation potential. Industry partners can also reduce the costs incurred during their research and development stage by licensing technology from a university. Another benefit for the university involves using the licensing revenue to support further research and education at the institution. Universities protect their investments in research by patenting new technologies, which gives them an opportunity to reach the stream of commerce. The university's investments in the technology help stimulate local economic development. The ultimate beneficiary of technology transfer is the public, who benefits from both the products that reach the market and the jobs resulting from the development, manufacturing, and sale of products.

1.4 Impact of Technology on Society

Technology and society or technology and culture refers to cyclical co-dependence, co-influence, co-production of technology and society upon the other. Technology has become a huge part of every day societies life. When societies knows more about the development in a technology, they become able to advantage from it. When an innovation achieves a certain point after it is been presented and promoted, this technology becomes part of the society. Digital technology has entered each process and activity made by the social system. The impact of technologies on society can broadly studies by dividing aspects of societies as

1. Education

Modern technologies have made instructive information for classrooms and home assignments easier and simpler. It provides children, who have difficulties in learning the traditional way, with educational games that would help them in the process of learning. Alternatively from attending classes, online courses are offered to college students in advantage. The progress of the innovation of technology is continuing to improve the education sector for coming generations. Students today are called 'screenagers', 'digital natives' or 'digital kids' because they were born in a complicated digital world based on technology.

Teachers are using digital technology as an essential tool to help in guiding lessons and student's communication. In fact, computers have been in the education frame globally for a long period of time. Students are associating with others more globally and learning more things in varied ways than at any time in the past.

2. Economic System

In the modern world, superior technologies, resources, geography, and history give rise to robust economies; and in a well-functioning, robust economy, economic excess naturally flows into greater use of technology. Moreover, because technology is such an inseparable part of human society, especially in its economic aspects, funding sources for (new) technological endeavors are virtually illimitable. However, while in the beginning, technological investment involved little more than the time, efforts, and skills of one or a few men, today, such investment may involve the collective labor and skills of many millions.

3. Politics

It is clear that gaining political publicity through the use of technology has become easier, especially since technological devices are so accessible and widespread at the same time. The article analyzed is good in arranging technological tools into separate groups that work as effective means of communication between a political figure and the target audience. However, to every coin there is a flip side. With the use of Internet, any political figure can become recognizable within just a few minutes. In only a few hours public opinion on a particular political figure is already formed within one of the social groups of voters. So, not just the good, but also a bad reputation can be formed in a blink of an eye using modern technology. It often happens that the bad "gossip" actually spreads much faster. So, with the huge impact that technology has on society and public opinion in particular, it is crucial to be cautious in the use of information about any political figure, or you risk making a positive advertisement into a negative advertisement with just one click.

4. Religion

Religions can use electronic technologies to propagate their beliefs. It seems that religious organisations still obtain favoured treatment on early morning TV, more so than other groups in society. However, those who believe voluntary euthanasia is a good option are forbidden to use electronic means to distribute information.

Religions can propagate their views more widely using global technologies such as over the internet. Others can propagate alternative views, but mainstream religions are well funded and run by zealots. There is a danger that the indoctrination of children, discrimination and the imposition of religious values on others could worsen before it improves.

There are many websites that propagate untruths about science and religion, seek money for 'truths' about imaginary beings, advocate discrimination or that gods can kill or do inappropriate things. Freedom of speech is important, but well-funded religions can propagate untruths and discriminatory values faster than less well-funded organisations.

In summary impact on religion can be viewed as

- (a) Its more accessible
- (b) Distance doesnt matter as much
- (c) Reputations are shifting
- (d) Stats become important
- (e) Laity gets involved
- (f) Theres increased focus on strategy

5. Environment

Technology provides an understanding, and an appreciation for the world around us. Most modern technological processes produce unwanted by products in addition to the desired products, which is known as industrial waste and pollution. While most material waste is re-used in the industrial process, many forms are released into the environment, with negative environmental side effects, such as pollution and lack of sustainability. Different social and political systems establish different balances between the value they place on additional goods versus the disvalues of waste products and pollution. Some technologies are designed specifically with the environment in mind, but most are designed first for economic or ergonomic effects.

Historically, the value of a clean environment and more efficient productive processes has been the result of an increase in the wealth of society, because once people are able to provide for their basic needs, they are able to focus on less-tangible goods such as clean air and water.

The effects of technology on the environment are both obvious and subtle. The more obvious effects include the depletion of non-renewable natural resources (such as petroleum, coal, ores), and the added pollution of air, water, and land. The more subtle effects include debates over long-term effect(e.g., global warming, deforestation, natural habitat destruction, coastal wetland loss.)

Each wave of technology creates a set of waste previously unknown by humans: toxic waste, radioactive waste, electronic waste.

Suman Sedhai (068DEX444)

Chapter 2

Energy Basics

2.1 Energy

Energy is defined as ability or Capacity to do work. Work has a very broader meaning to Scientist and Engineers. Non-technical people can think energy as the ability of doing diverse things in life. Energy is not a thing or substance but idea or a theoretical concept to connect diverse process like, Burning Fuels , Propelling machines, Charging Batteries. Although appearing different ,they have a number of common feature and describing these features leads to greater understanding of energy. Energy has many forms and can be converted from one to another.

- Kinetic Energy: Energy possessed by moving object E.g. Wind ,Water in Streams. Speed and mass of object influence in amount of total kinetic energy. Faster the wind or more the flowing water more the energy.
- Potential Energy: Energy Possessed by object's position relative to earth, This energy will be converted to kinetic energy, if the object fall for example, water behind the dam.
- Thermal Energy (heat): A form of kinetic energy due to random motion of the atoms or molecules of solid gases or liquid. Faster the atoms or molecules move, greater will be the thermal energy of the object.
- Chemical Energy: A form of energy stored in atoms or molecules Usually chemical energy is converted to heat (combustion) or electrical energy (batteries).
- Electrical Energy: It is one of the most familiar form. The Organized flow of electrons in a material can be considered as electrical energy.
- Electromagnetic Energy(radiation): This is form of electrical and magnetic energy which all objects ,in different amounts radiate or emit. The most familiar form is light.
- Mechanical Energy: Energy of rotation usually associated with rotating shaft.

In an energy conversion process two things are important: Quantities of energy involved and Rate at which energy is converted . Rate per second at which energy is converted is called the power. Mathematically,

$$Energy = power \times time$$

There are many ways of measuring the energy. Joule (abbreviated as J) is the Standard Unit or SI unit of Energy

Calories also common unit

British Thermal Unit (BTU) Particularly used when talking about steam

Tonnes of Coal Equivalent (TCE)

Tonnes of Oil Equivalent (TOE)

$$\begin{aligned}
 1\text{Calorie} &= 4.182\text{J} \\
 1\text{BTU} &= 1055\text{J} \\
 1\text{TCE} &= 29.31\text{GJ} \\
 1\text{TOE} &= 41.868\text{GJ}
 \end{aligned}
 \tag{2.1}$$

Power is mainly measured in watts (abbreviated as W) . 1 watt is defined as power produced when converting 1 joule of energy per second. For the case involving large amount Kilo, Mega, Giga prefixes are used.

$$1\text{KW}=1000\text{W and } 1\text{MW}=10^6\text{W}$$

Form of energy can also be indicated in the output from a particular piece of equipment. When one form

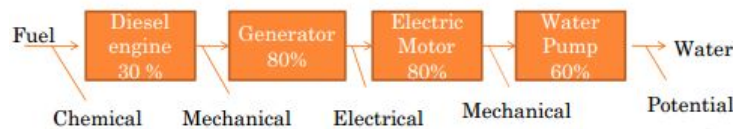

Figure 2.1.1: Effect of intermediate process while calculating efficiency.

of energy is converted into other for a particular purpose, not all the energy is converted, certain energy is wasted or lost to the process. The ratio of Useful energy to Energy Input is the efficiency.

The Process of energy conversion generally comprises of number of intermediate transformations or stages with their own conversion efficiency Overall system efficiency is found by multiplication of efficiencies of each stage. As the number of stages increases the overall system efficiency decreases.

$$\text{Overall system Efficiency} = 30\% \times 80\% \times 80\% \times 60\% = 12\%$$

One way to increase the efficiency is to use the wastage energy (espheat) The heat energy from exhaust gases from boiler can be used via heat exchanger. E.g. in agro-processing factory this heat energy can be used for drying the product co-generation or combined heat and power (CHP) uses this idea. E.g. In a sugar industry: The bagasse or sugarcane fibres are used as fuel for generating electricity using a turbine. Heat remaining in the exhaust gas is used to evaporate water from raw cane juice which is the part of extraction process. The overall efficiency of the Co-generation system can be 80% or higher.

The energy conversion from original source to the useful form generally take place in number of stages. The energy flows from one to other form at each conversion ,transformation or transport step. These steps can be considered as a chain and the energy in this chain can be classified into:

1. Primary Energy: Energy in the form available in natural environment
2. Secondary Energy: Energy Ready for transport or transmission
3. Final Energy: Energy the consumer buys or receives.
4. Useful energy: Energy actually required to perform the work.

2.2 Classification of Energy Sources

1. Biomass Energy: Any material of plant or animal origin such as biomass, agricultutal residue, animal and human faeces. They can be converted to solid, liquid or gaseous fuel through various processes but they needs some processing stage such as chopping, mixing, drying etc. before conversion.
2. Solar Energy: Energy from the sun as either direct or diffuse radiation. Direct radiation is collected when collector (leaf or solar panel) faces the sun. Diffuse radiation comes from every direction and is present even on cloudy day. Solar Energy is converted to heat through thermal solar devices and to electricity through photovoltaic cells.

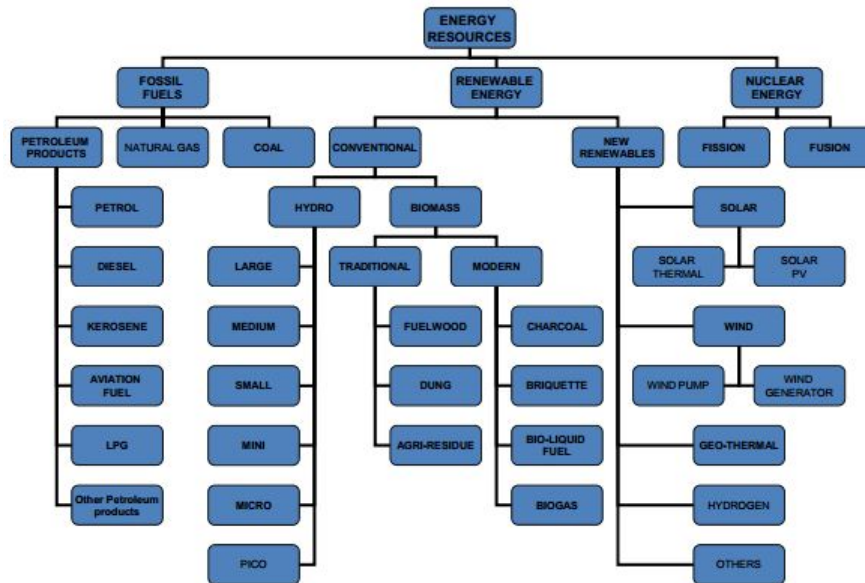

Figure 2.2.1: Classification of energy resources.

3. Hydro Energy: The potential energy from the water stored behind dams, weirs or water falls. The kinetic energy of streams or rivers Water wheels and hydro turbines are used to convert the energy to mechanical or electrical energy.
4. Wind Energy: The Kinetic energy from the wind is converted by wind turbines into mechanical energy or electrical energy.
5. Geothermal Energy: Heat energy flowing from the earth's core to surface by molten rocks or hot water. This heat energy can be used for spacing heating, drying or electricity generation.
6. Animate Energy: Energy delivered by humans and animals. Major source of energy in agriculture in developing countries but they never appear in national energy balances.
7. Ocean Energy: Includes Wave Energy and Ocean Thermal Energy (heat flow between the warm surface and cool deep water)
8. Fossil Fuels: Coal, Crude Oil and natural gas are sources of energy.
9. Nuclear Energy: Energy released when nuclei of atoms break apart This huge energy is utilized by converting to electrical energy.

Energy Sources are sometimes classified under heading as:

1. **Renewable:** Source of energy not depleted by use such as wind energy, solar energy are renewable sources of energy. Biomass can be renewable if regrow this matched by consumption. New and Renewable covers all renewable energy plus geothermal and ocean energy.
2. **Traditional and Non-Traditional Energy:** It depends on the users perspective. Many biomass users would be regarded as traditional and fossil fuel as non-Traditional. Wood can be considered as traditional but when used in a gasifier if it produces non traditional source.
3. **Modern:**
4. **Commercial:** Refers to those energy for which have to be paid for example fossil fuels, biomass is usually classified as non-commercial but it depends where we are in the world.
5. **Conventional**

2.3 Importance of Energy in achieving Maslow's hierarchy of Needs

2.3.1 Maslow's Hierarchy of Needs or Theory of Human Needs

There is hierarchy of needs. People satisfy the most pressing need first. The needs are:

Physiological Needs

The survival needs for food, water, shelter etc. Man who is missing everything in life in an extreme fashion, the major motivation would be the physiological needs. A person who is lacking food, safety, love, and esteem would most probably hunger for food more strongly than for anything else. If all the needs are unsatisfied, and the organism is then dominated by the physiological needs.

Safety Needs

Needs that protects from physical harm and economic deprivation. If the physiological needs are fulfilled, there then emerges a new set of needs, which we may categorize roughly as the safety needs. Again, as in hungry man, we find that the dominating goal is a strong determinant not only of his current world-outlook and philosophy but also of his philosophy of the future. Practically everything looks less important than safety (even sometimes the physiological needs which being satisfied, are now underestimated).

Social Needs

These needs are sense of belongingness, friendship, affection, love etc. If both the physiological and the safety needs are fairly well gratified, then there will emerge the love and affection and belongingness needs repeat itself with this new centre. Now the person will feel keenly, as never before, the absence of friends, or a sweetheart, or a wife, or children. He will hunger for affectionate relations with people in general, namely, for a place in his group, and he will strive with great intensity to achieve this goal. He will want to attain such a place more than anything else in the world and may even forget that once, when he was hungry, he sneered at love.

Ego or Esteem Needs

These types of needs are like respect, recognition, status, praise, prestige, etc. All people have a need or desire for a stable, firmly based, high evaluation of themselves, for self-respect, or self-esteem, and for the esteem of others. By firmly based self-esteem, we mean that which is soundly based upon real capacity, achievement and respect from others. The desire for strength, for achievement, for adequacy, for confidence in the face of the world, and for independence and freedom, for reputation or prestige (defining it as respect or esteem from other people), recognition, attention, importance or appreciation are esteem needs.

Satisfaction of the self-esteem need leads to feelings of self confidence, worth, strength, capability and adequacy of being useful and necessary in the world. Lack of these needs produces feelings of inferiority, of weakness and of helplessness.

Self Actualization Needs

These types of needs include creativity, self development, self fulfilment, etc. Even if all prior needs are satisfied, we may still often (if not always) expect that a new discontent and restlessness will soon develop, unless the individual is doing what he is fitted for. A musician must make music, an artist must paint, a poet must write, if he is to be ultimately happy. What a man can be, he must be. This need we may call self-actualization.

It refers to the desire for self-fulfilment, namely, to the tendency for him to become actualized in what he is potentially. This tendency might be phrased as the desire to become more and more what one is, to become everything that one is capable of becoming. The specific form that these needs will take will of course vary greatly from person to person. In one individual it may take the form of the desire to be an ideal mother, In another it may be expressed athletically, and in still another it may be expressed in painting pictures or in inventions. It is not necessarily a creative urge although in people who have any capacities for creation it will take this form.

The clear emergence of these needs rests upon prior satisfaction of the physiological, safety, love and esteem needs.

2.4 Human Development Index

A tool developed by the United Nations to measure and rank countries' levels of social and economic development based on four criteria: *Life expectancy at birth, mean years of schooling, expected years of schooling and gross national income per capita.*

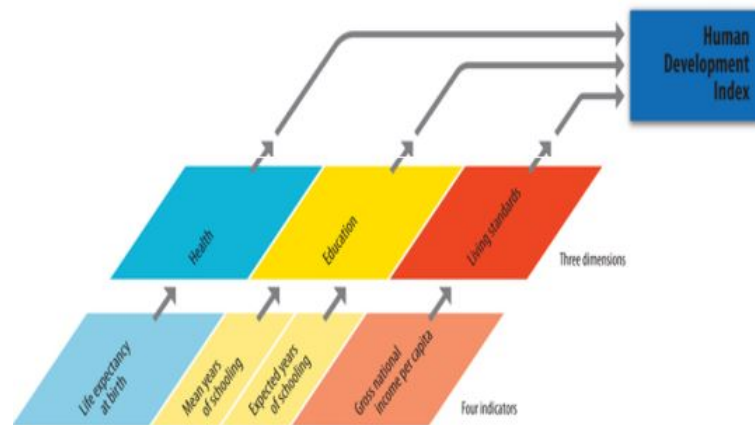

Figure 2.4.1: HDI dimension and parameters.

The HDI makes it possible to track changes in development levels over time and to compare development levels in different countries. UNDP publishes Human Development Report (HDR). The first HDR introduced a new way of measuring development by combining indicators of life expectancy, educational attainment and income into a composite human development index, the HDI. The breakthrough for the HDI was the creation of a single statistic which was to serve as a frame of reference for both social and economic development. The index also shows that countries with lots of income do not always spend that money in ways that create high life expectancies or education levels. The HDI sets a minimum and a maximum for each dimension, called goalposts, and then shows where each country stands in relation to these goalposts, expressed as a value between 0 and 1.

HDI shows the relation between life expectancy, education and income. The report shows the poor people are lower at the Energy Ladder.

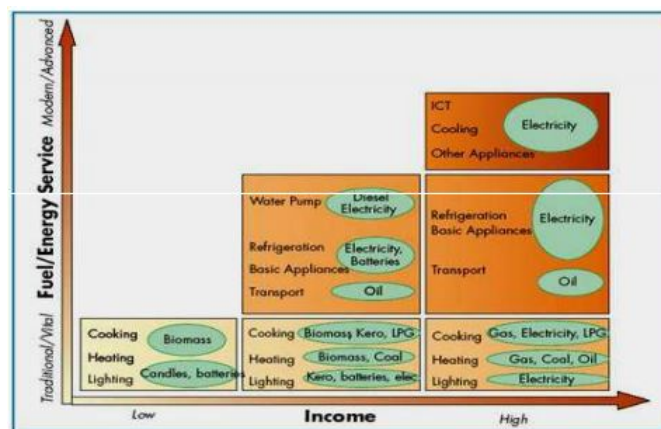

Figure 2.4.2: Energy Ladder diagram for income vs Fuel/Energy Service.

The report published by UNDP/World Bank on 2013 shows Norway on 1st place with HDI of 0.944, electricity consumption per capita 23549.68992, income per capita(PPPUS\$)63,909 and Nepal in 145th position with HDI of 0.540, electricity consumption per capita of 90.9531266 and income per capita(PPPUS\$)2,194.

The Human Development Index (HDI) is a summary measure of average achievement in key dimensions of human development: a long and healthy life, being knowledgeable and have a decent standard of living. The HDI is the geometric mean of normalized indices for each of the three dimensions.

The health dimension is assessed by life expectancy at birth component of the HDI is calculated using a minimum value of 20 years and maximum value of 85 years. The education component of the HDI is measured by mean of years of schooling for adults aged 25 years and expected years of schooling for children of school entering age. Mean years of schooling is estimated by UNESCO Institute for Statistics based on educational attainment data from censuses and surveys available in its database. Expected years of schooling estimates are based on enrolment by age at all levels of education. This indicator is produced by UNESCO Institute for Statistics. Expected years of schooling is capped at 18 years. The indicators are normalized using a minimum value of zero and maximum aspirational values of 15 and 18 years respectively. The two indices are combined into an education index using arithmetic mean.

The standard of living dimension is measured by gross national income per capita. The goalpost for minimum income is \$100 (PPP) and the maximum is \$75,000 (PPP). The minimum value for GNI per capita, set at \$100, is justified by the considerable amount of unmeasured subsistence and nonmarket production in economies close to the minimum that is not captured in the official data. The HDI uses the logarithm of income, to reflect the diminishing importance of income with increasing GNI. The scores for the three HDI dimension indices are then aggregated into a composite index using geometric mean. Refer to Technical notes for more details.

The HDI does not reflect on inequalities, poverty, human security, empowerment, etc. The HDRO offers the other composite indices as broader proxy on some of the key issues of human development, inequality, gender disparity and human poverty.

A fuller picture of a country's level of human development requires analysis of other indicators and information presented in the statistical annex of the report.

2.5 Current Energy Trends, Demand and Supply of Energy in World and Nepal

2.5.1 Energy Trends, Demand and Supply in World

(<https://sushil99.wordpress.com/2009/03/12/electricity-crisis-in-nepal-what-can-be-a-viable-solution/>) Energy demand is expected to increase considerably in the coming years as the result of population growth and economic development (EIA, 2007). Many people in the world are currently experiencing dramatic shifts in lifestyle as their economies make the transition from a subsistence to an industrial or service base. The largest increases in energy demand will take place in developing countries where the proportion of global energy consumption is expected to increase from 46 to 58 percent between 2004 and 2030 (EIA, 2007). Per capita consumption figures are, however, likely to remain well below those in Organisation for Economic Co-operation and Development (OECD) countries.

Energy consumption in developing countries is projected to grow at an average annual rate of 3 percent from 2004 to 2020. In industrialized countries, where national economies are mature and population growth is expected to be relatively low, the demand for energy is projected to grow at the lower rate of 0.9 percent per year, albeit from a much higher starting point. Energy consumption in developing regions is projected to surpass that in industrialized regions by 2010. About half of the increase in global energy demand by 2030 will be for power generation and one-fifth for transport needs mostly in the form of petroleum-based fuels (EIA, 2007).

Much of the increase in energy demand will result from rapid economic growth in Asian economies, especially China and India. Energy demand in the developing countries of Asia is projected to grow at an average rate of 3.7 percent per year, far higher than any other region. Asia will more than double its energy consumption over the next 20 years, and is expected to account for around 65 percent of the total increase in energy demand for all developing countries. Although the energy consumption of developing countries in other regions is expected to grow at a slower pace than in Asia, rates are still expected to exceed the global average. While all regions will play a role in future energy supply and demand, the enormous consumption increases projected in Asia make the region of key interest in future energy development.

The vast majority of the world's energy is generated from non-renewable sources, specifically oil, coal and gas. Just over 13 percent of global energy is derived from renewable sources, 10.6 percent of which from combustible renewables and renewable municipal waste. The remainder of renewable energy comes from hydro-, geothermal, solar, wind, and tidal and wave sources.

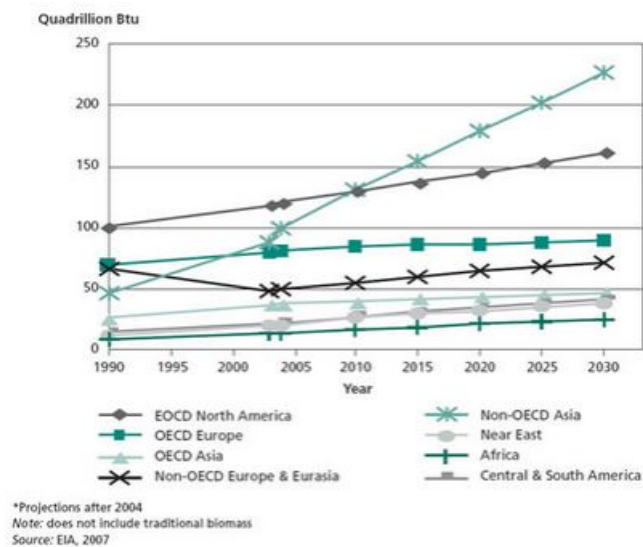

Figure 2.5.1: Total marketed energy consumption.

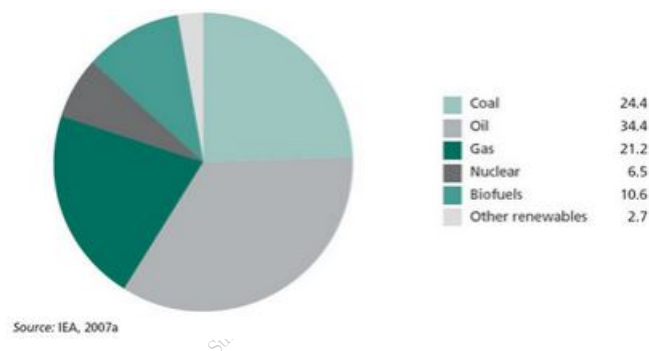

Figure 2.5.2: Fuel shares of world energy supply.

Projections of total global energy consumption show that between 2004 and 2030, fossil fuels will provide the bulk of the increase, with nuclear and other sources providing relatively minor contributions in absolute terms. In percentage terms, gas and coal are likely to show the greatest change with increases of 65 and 74 percent respectively. Oil consumption is expected to increase by 42 percent while nuclear and renewables, starting from a much lower baseline, are expected to increase by 44 and 61 percent respectively. The ultimate contributions from different sources will be highly dependent on policy directions.

2.5.2 Energy Trends, Demand and Supply in Nepal

About 6,000 rivers, with a total length of about 45,000 km with an annual discharge of 220 billion cubic meters of water are available in the country. The commercial potential of hydro-power in Nepal are said to be about 83,000 MW and 42,000 MW respectively. So far only about 603 MW have been connected to peak load system, which constitute about 1.88% of total energy supply. Forests supply nearly 78% of the total energy requirement of the country, and also provide 50% of fodder for livestock purpose. On average Nepal has 6.8 sunshine hours per day, i.e. 2,482 sunshine hours per year with the intensity of solar insolation ranging from 3.9 to 5.1 $kWh/m^2/day$. (National average is about 4.7 $kWh/m^2/day$). Though significant wind potential is noted to be available in mountainous region (Mustang district, Khumbu region, Palpa, Ramechhap, Karnali Chisapani, Jumla) no proper wind mapping of Nepal has been done so far.

Energy consumption by source in Nepal can be divided into three categories: traditional, commercial and renewable. The traditional source meets the bulk of total energy consumption with an 85.5 per cent share, followed by commercial and renewable energy sources at 13.54 per cent and 0.61 per cent, respectively. Fuel wood, agriculture residue and animal residue provide 88.68 per cent, 4.85 per cent and 6.47 per cent of the total traditional energy consumption, respectively. Nepal is at lowest in the list of

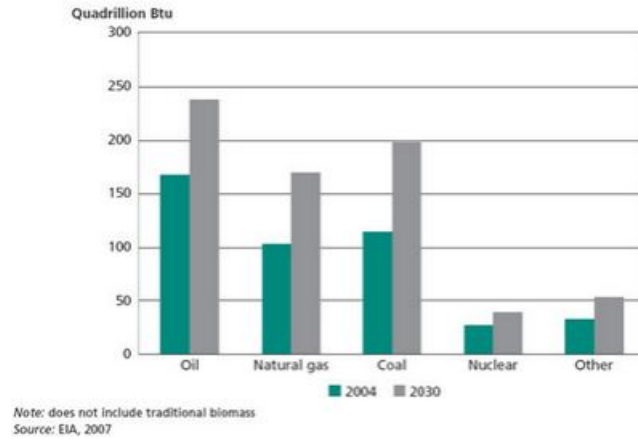

Figure 2.5.3: Total global marketed energy consumption by source in 2004 and projected for 2030.

ascending hierarchy in per capita electrical energy consumption among the other SAARC countries which accounts just 68 KWh in 2003, a slightly inclined from 35 in 1990 status.

Present Trend

National energy demand of Nepal is 11.6 million units. The energy system manages to support demand of 6.2 million units of energy which account to be 55 per cent of the demand. The total installed capacity of hydro plants is 619.38 MW and runs with production capacity of 276MW at present. The annual demand of electricity has been steadily inclined by 9.3 per cent which indicates the new plant of size 60-80 MW addition to meet the growing need of domestic market. It has been a tough time to NEA to manage even 326 MW power at its mettle. The shortage of 534 MW power over the demand has pushed to darkest years in the history of electricity development and crippling hours of load shedding has slowly turned to be way of life among people. Thus, Government of Nepal has declared "National Electricity Crisis" in Nepal.

Causes

1. Supply lag over demand
2. Monopoly of NEA
3. Resource deficit
4. Inadequate private investment
5. Failure to meet development target
6. Seasonal variation in supply
7. Lack of timely maintenance
8. Lack of chain development initiative

Effects

1. Withering linkages: Energy is an important input in production process in an economy power shortage has bound industries to cut down production heavily if not shut down factories both service and goods reduction industries of small to larger scale have been struggling to exist.
2. Reduces national revenue and income: The power cuts has drastically declined the production the revenue of government collected informs of taxes and fees /prices is being low. As there is direct as well as spell over effects of hydro projects in GDP and per capita income, the development in the sector helps to ease the livelihoods of people and increase the income.
3. Cut-down of jobs: Due to weakening financial strength many workers have already been laid off and it seems to continue unless regular power resumes.

4. Increment of social crimes: There has been frequent report of increased social crimes such as incidence of theft robbery at the time of load shedding.
5. Reduction in investment: Power is a pre-condition for investment and no investor would like to invest in such places where no power is available 24hrs for industry.

Issues

1. Institutional development: The ongoing problem definitely doesn't deny the fact of failure and supports the voice to arrangement of independent entity in-charge of energy development.
2. Alternative sources: Energy in Nepal has been envisaged as hydropower due to its potentiality and coverage. Till date, alternative sources of energy are taken as for rural setting where national grid takes years to connect. Harvest of solar power help even the urban dwellers to meet their household demand.
3. Public-private partnership: It is the only way to generate resources to fill the resource gap prevailed in development sector in Nepal. It curtails aid syndrome and sever conditionality intermingle with it.
4. Political commitment: Political commitment is the must for sustainable energy development consensus based policy on energy sector is needed among the brands to capitalize national potential.
5. Micro-macro project debate: The scope of power plants is matter of national debate even among the policy makers. They clearly saw in two contrasting opinions. Some advocate on small hydro-plants for rural electrification and claims to be realistic, given the present resources constraints and feasibility. The need of larger project is the only options as other urges.
6. Integrated energy development: The potential alternative sources are not developed at satisfactory level yet manage their existence at rural settings. Integrated energy policy (IEP) is an issue in the situation such as envisaged in power sector now-a-days.
7. Infrastructure development: Access road and transmission line to connect national grid are essential pre-condition for any projects. It is blame that PPA of many projects is subjected to the availability of such infrastructures. License holders and private entrepreneurs are not in position to start their proposed projects due to lack of such infrastructure.

2.6 Introduction to Global Warming

Global warming is the term used to describe a gradual increase in the average temperature of the Earth's atmosphere and its oceans, a change that is believed to be permanently changing the Earth's climate. Global warming is caused by emission of Green House Gas(GHG) due to natural and man made processes

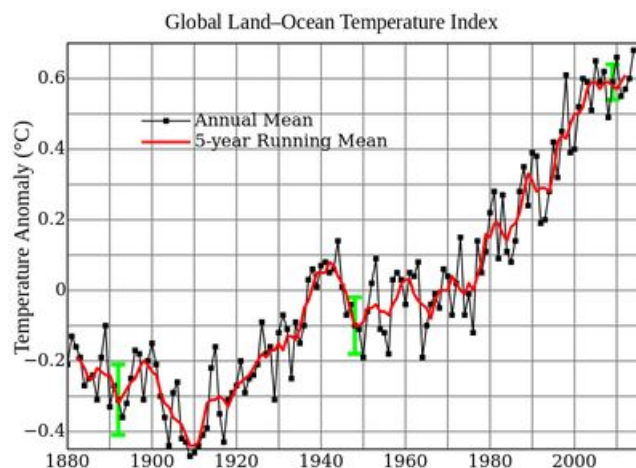

Figure 2.6.1: Temperature variation in earth.

which will not allow sunlight to reflect back from earth and cause green house effect causing temperature rise in earth.

Radiation balance change can be done by:

- By changing the incoming solar radiation
- By changing the fraction of solar radiation that is reflected (called 'albedo')
- by altering the long wave radiation from Earth back towards space

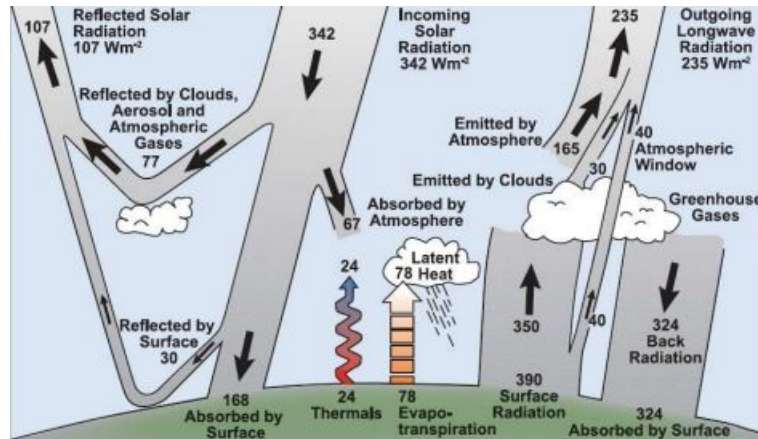

Figure 2.6.2: Radiation energy balance adopted by IPCC(2007).

Atmospheric constituents changes are expressed in radiative forcings. The global atmospheric concentration of carbon dioxide has increased from a preindustrial value of about 280 ppm to 379 ppm in 2005. The annual carbon dioxide concentration growth rate was larger during the last 10 years (1995-2005 average: 1.9 ppm per year) years (1995-2005 average: 1.9 ppm per year). Fossil fuel use with land-use change are the primary sources. The global atmospheric concentration of methane has increased from a preindustrial value of about 715 ppb to 1732 ppb in the early 1990s, and was 1774 ppb in 2005. The global atmospheric nitrous oxide concentration increased from a pre-industrial value of about 270 ppb to 319 ppb in 2005.

A concept used for quantitative comparisons of the strength of different human and natural agents in causing climate change (Wm^{-2}). Human activities and natural processes cause direct and indirect changes in climate change drivers. These changes result in specific RF changes, either positive or negative and non initial radiative effects. There is very high confidence that the global average net effect of human activities since 1750 has been one of warming, with a radiative forcing of $+1.6 [+0.6 \text{ to } +2.4] Wm^{-2}$.

Most countries are parties to the United Nations Framework Convention on Climate Change (UNFCCC), whose ultimate objective is to prevent dangerous anthropogenic climate change. The UNFCCC have adopted a range of policies designed to reduce greenhouse gas emissions and to assist in adaptation to global warming. Parties to the UNFCCC have agreed that deep cuts in emissions are required, and that future global warming should be limited to below $2^{\circ}C$ ($3.6^{\circ}F$) relative to the pre-industrial level.

Future climate change and associated impacts will be different from region to region around the globe. The effects of an increase in global temperature include a rise in sea levels and a change in the amount and pattern of precipitation, as well as a probable expansion of subtropical deserts. Warming is expected to be strongest in the Arctic, with the continuing retreat of glaciers, permafrost and sea ice. Other likely effects of the warming include more frequent extreme weather events including heat waves, droughts, heavy rainfall, and heavy snowfall; ocean acidification; and species extinctions due to shifting temperature regimes. Effects significant to humans include the threat to food security from decreasing crop yields and the loss of habitat from inundation.

Over the period 1961 to 2003, global ocean temperature has risen by $0.1^{\circ}C$ from the surface to a depth of 700m. From 1961 to 2003, the average rate of sea level rise was $1.8 \text{ } 0.5 \text{ mm yr}^{-1}$.

Out of 2323 glacial lakes reported in Nepal (ICIMOD, 2001), 20 lakes are found potentially dangerous. Almost 20 % of the glaciated area above 5000 m is likely to be snow and glacier free area at an increase of air temperature by $1^{\circ}C$. Such changes in glacier areas are likely to contribute to the development of glacier lakes increasing potential GLOF hazards

2.6.1 Kyoto Protocol and Clean Development Mechanism

The Kyoto Protocol is an international treaty, which extends the 1992 United Nations Framework Convention on Climate Change (UNFCCC) that commits State Parties to reduce greenhouse gases emissions, based on the premise that (a) global warming exists and (b) man-made CO₂ emissions have caused it. The Kyoto Protocol was adopted in Kyoto, Japan, on 11 December 1997 and entered into force on 16 February 2005. There are currently 192 Parties involved.

The Kyoto Protocol implemented the objective of the UNFCCC to fight global warming by reducing greenhouse gas concentrations in the atmosphere to 'a level that would prevent dangerous anthropogenic interference with the climate system' (Art. 2). The Protocol is based on the principle of common but differentiated responsibilities: it puts the obligation to reduce current emissions on developed countries on the basis that they are historically responsible for the current levels of greenhouse gases in the atmosphere.

Three "flexibility mechanisms" identified in the Kyoto Protocol can be used to meet their GHG reduction targets are:

- CDM
- JI
- IET

The CDM is the only mechanism under the Kyoto Protocol that involves developing countries, or non-Annex I countries.

The Clean Development Mechanism (CDM) is one of the flexibility mechanisms defined in the Kyoto Protocol (IPCC, 2007) that provides for emissions reduction projects which generate Certified Emission Reduction (CER) units which may be traded in emissions trading schemes.

The CDM is defined in Article 12 of the Protocol, and is intended to meet two objectives:

- To assist parties not included in Annex I in achieving sustainable development and in contributing to the ultimate objective of the United Nations Framework Convention on Climate Change (UNFCCC), which is to prevent dangerous climate change; and
- To assist parties included in Annex I in achieving compliance with their quantified emission limitation and reduction commitments (greenhouse gas (GHG) emission caps)

Where, Annex I parties are those countries that are listed in Annex I of the treaty, and are the industrialized countries. Non-Annex I parties are developing countries.

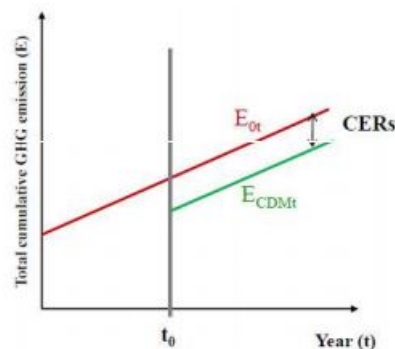

Figure 2.6.3: CDM baseline.

The CDM addresses the second objective by allowing the Annex I countries to meet part of their emission reduction commitments under the Kyoto Protocol by buying Certified Emission Reduction units from CDM emission reduction projects in developing countries. The CDM is supervised by the CDM Executive Board (CDM EB) and is under the guidance of the Conference of the Parties (COP/MOP) of the United Nations Framework Convention on Climate Change (UNFCCC).

The CDM allows industrialized countries to buy CERs and to invest in emission reductions where it is cheapest globally.

CER and Baseline Concepts

The baseline for a CDM project activity is the scenario that reasonably represents the anthropogenic emissions by sources of greenhouse gases that would occur in the absence of the proposed project activity. The baseline is defined on a project specific basis. The baseline refers to hypothetical future emissions that would occur if the proposed CDM project activity is not implemented (see Figure 2.6.3).

Where, t_o = Starting year of CDM

E_{0t} = Total emission without CDM

E_{CDMt} = Total emission with CDM

$CER = E_{0t} - E_{CDMt}$ TOE CO_2 reduction (tradable in international market)

Eligible Projects for CDM

Renewable energy, Fuel switching, End-use energy efficiency improvements, Supply-side energy efficiency improvements, Waste handling and disposal, Agriculture (reduction of CH_4 and N_2O emissions), Industrial processes (CO_2 from cement, HFCs, etc.), Sink projects (only afforestation and reforestation).

The small scale CDM projects can be:

1. **Type I:** RE projects with a maximum output capacity equivalent to up to 15 megawatts (or an appropriate equivalent)
2. **Type II:** energy-efficiency improvement project activities which reduce energy consumption on the supply and/or demand side by up to the equivalent of 15 gigawatt-hours per year
3. **Type III:** other project activities that both reduce anthropogenic emissions by sources and directly emit less than 15 kilotonnes of CO_2 equivalent (CO_2e) annually.

CDM Opportunities in Nepal

1. **Renewable energy:** CDM can be helpful for power generation and utilizations like Micro hydro power generation, Solar energy power: heating, lighting, power, Biomass based energy: power, heating, Wind based power generation, Geo-thermal energy utilization: heating, cooling, power generation.
2. **Transportation:** Low GHG emitting vehicles, Bus Rapid Transit Projects, Energy efficiency by using, retrofit technologies
3. **Waste Management:** Methane recovery, Capturing/Avoiding the landfill gas emissions, Waste-to-energy and Biological treatment of the biomass
4. **Afforestation / Reforestation:** Creation of carbon sinks in addition to what is required under regulations, reforestation and afforestation of degraded land.
5. **Bio-fuels** Plant oil production and use for transport application, production of biodiesel based on waste oils and/or waste fats from biogenic origin for use as fuel.
6. **Energy Efficiency:** Process optimization: new technology, retrofits, building energy efficient power generation, distribution, lighting technology.

2.7 Conventional/Non conventional and Renewable/Non Renewable Energy Sources

2.7.1 Conventional/Non conventional Energy Sources

Conventional Energy Sources

The conventional sources of Energy includes : Coal, petroleum natural gas, hydropower etc. Since, their uses are practiced for a long time. They are exhaust able except water. They cause pollution when used, as they emit smoke and ash. They are very expensive to be maintained, stored and transmitted as they are carried over long distance through transmission grid and lines.

Non Conventional Energy Sources

The resources which are yet in the process of development over the past few years. It includes solar, wind, tidal, biogas, and biomass, geothermal. They are inexhaustible. They are generally pollution free and are less expensive due to local use and easy to maintain. The Non-conventional sources of energy includes : Solar Energy, tidal energy, geo-thermal energy, wind energy, nuclear energy etc.

2.7.2 Renewable/Non Renewable Energy Sources

Renewable Energy Sources

Our renewable energy resources will never run out. Their supply is not limited. There are no fuel costs either. And they typically generate far less pollution than fossil fuels. Renewable energy resources include: wind energy, water energy, such as wave machines, tidal barrages and hydroelectric power geothermal energy, solar energy, biomass energy.

However, there are some negatives to generating renewable energy. For example, wind farms are noisy and may spoil the view of people who live near them. The amount of electricity generated depends on the strength of the wind. Also, if there is no wind, there is no electricity.

Non Renewable Energy Sources

There is a limited supply of non-renewable energy resources, which will eventually run out. They include: fossil fuels, such as coal, oil and natural gas nuclear fuels, such as uranium, etc.

Fossil fuels release carbon dioxide when they burn, which adds to the greenhouse effect and increases global warming. Of the three fossil fuels, coal produces the most carbon dioxide, for a given amount of energy released, while natural gas generates the least.

The fuel for nuclear power stations is relatively cheap. But the power stations themselves are expensive to build. It is also very expensive to dismantle old nuclear power stations or store radioactive waste, which is a dangerous health hazard.

2.7.3 Nuclear power stations

The main nuclear fuels are uranium and plutonium, both of which are radioactive metals. Nuclear fuels are not burned to release energy. Instead, heat is released from changes in the nucleus.

Just as with power stations burning fossil fuels, the heat energy is used to boil water. The kinetic energy in the expanding steam spins turbines, which drive generators to produce electricity.

Some advantages are unlike fossil fuels, nuclear fuels do not produce carbon dioxide.

And some disadvantages are like fossil fuels, nuclear fuels are non-renewable energy resources. And if there is an accident, large amounts of radioactive material could be released into the environment. In addition, nuclear waste remains radioactive and is hazardous to health for thousands of years. It must be stored safely.

Suman Sedhai (068DEX444)

Chapter 3

Renewable Energy Sources

3.1 Solar Energy

The sun is a sphere of intensely hot gaseous matter. It has diameter of 1.39×10^9 m and is about 1.5×10^{11} m away from the earth. It rotates on its axis about once every four weeks as seen from earth. However, it does not rotate as a solid body: the equator takes about 27 days and the polar regions take about 30 days for each rotation. It is a continuous fusion reactor. The temperature of the core is estimated to be around 10^7 K. The energy created by the fusion reaction is transferred out to the surface in a succession of radiative and convective process and finally radiated into the space.

The sun radiates in all regions of the spectrum, from radio waves to gamma rays. Our eyes are sensitive to less than one octave of this, from 400 to 750 THz (750 to 400 nm), a region known, for obvious reasons, as visible. Although narrow, it contains about 45% of all radiated energy. At the distance of one astronomical unit, the power density of the solar radiation is about 1367 Wm^{-2} , a value called **solar constant**, which is not really constant; it varies a little throughout the year, being largest in January when the earth is nearest the sun.

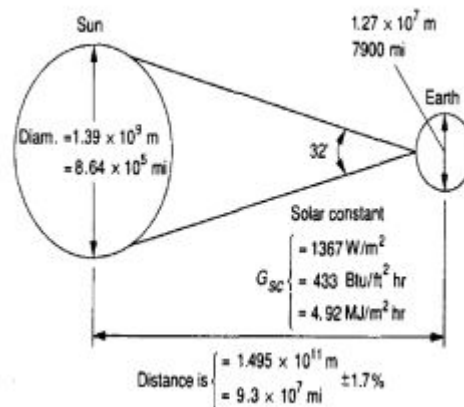

Figure 3.1.1: Sun and Earth.

The expression power density is used to indicate the number of watts per square meter. This is also known as energy flux. We will use the expression spectral power density to indicate the power density per unit frequency interval or per unit wavelength interval.

The power density of solar radiation on the ground is smaller than that in space owing to atmospheric absorption. Radiation of frequencies above 1000 THz ($\lambda < 300$ nm) is absorbed by the upper atmosphere causing photochemical reactions, producing photoionization, and generally heating up the air. However, this part of the spectrum contains only 1.3% of the solar constant. The ozone layer near 25 km altitude absorbs much of it. Ozone is amazingly opaque to ultraviolet. If the atmosphere were a layer of gas of uniform sea level density, it would be 8 km thick. The photovoltaic process converts solar radiation into useful electrical radiation. It can be considered the fuel for the electricity generation is the energy received from the sun in the form of radiation.

At least 30% of sunlight is attenuated during its passage through the earth's atmosphere. The main causes of such attenuation are:

- Rayleigh scattering or scattering by molecules in the atmosphere.
- Scattering by aerosols and dust particles.
- Absorption by the atmosphere and its constituent gases.

The degree of attenuation is highly variable. The important parameter for the incident power under clear conditions is the length of light path through the atmosphere referred as **Air Mass (AM)**. The total radiation at the earth's surface is the sum of direct radiation and diffused radiation.

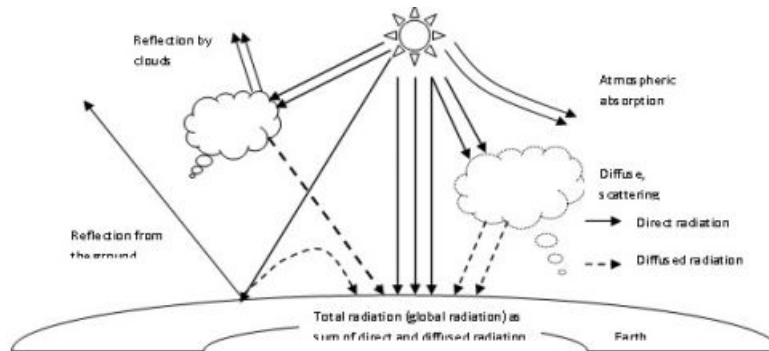

Figure 3.1.2: Arrival of solar energy on Earth .

3.1.1 Some Basic Terms

Solar Constant

The radiation emitted by the sun and its spatial relationship to the earth result in a nearly fixed intensity of solar radiation outside the earth's atmosphere. The solar constant is the energy from the sun per unit time, received on a unit area of surface perpendicular to the direction of propagation of the radiation at the earth's mean distance from the sun outside the atmosphere. The World Radiation Center (WRC) has adopted a value of 1367 W/m^2 as the solar constant.

Irradiance

Irradiance, I , is defined as the intensity of solar radiation per unit time on a unit surface area of the earth. The unit is taken as W/m^2 .

Insolation

Insolation is the total energy received from the sun in a day in a unit surface area on the earth. The unit of insolation is $\text{Wh/m}^2/\text{perday}$ For Nepal the yearly average insolation can be taken around 4500 to 5500 $\text{Wh/m}^2/\text{perday}$.

Peak Sun

Peak sun is the number obtained by division of insolation by $\text{Wh/m}^2/\text{perday}$. In most cases, the peak sun or the insolation is treated as a single parameter because they are interrelated by a constant coefficient.

Air Mass

Although radiation from the sun's surface is reasonably constant, when reaching the Earth it is highly variable due to absorption and scattering in atmosphere. When skies are clear, the maximum radiation strikes the Earth's surface when the sun is directly overhead, and sunlight has the shortest path length through the atmosphere. This path length is usually referred to as the *Air Mass*. Through which solar radiation must pass to reach the Earth's surface. The condition when the sun is directly overhead, the

distance through which the sun rays penetrate the atmosphere is shortest and is referred to as **Air Mass 1** or **AM1**. AM1.5 (equivalent to a sun angle of 48.2 from overhead or 41.8 from horizontal plane) has become the standard for photovoltaic standards. The air mass can be estimated at any location using the following formula:

$$AM = \sqrt{1 + (s/h)^2} \quad (3.1)$$

Where, s is the length of the shadows cast by a vertical post of height h .

For Photo Voltaic(PV) cell, it is important to face the array in an angle such that it permits the sunlight for maximum possible duration and intensity. The angle at which the module is inclined is called **tilt angle**. To determine the optimum tilt angle it will be necessary to locate the position of the sun from the given site on the earth. The position of a site on earth with respect to the sun is determined by two continuously changing angles, namely: the sun's hour and declination angles, and by one fixed angle that specifies a site's location on earth, namely the latitude.

Declination Angle

The sun's declination angle is the angular position of the sun at its highest point in the sky with respect to the plane of equator. It depends on the momentary position of the earth in its revolution around the sun. Changes in the declination angle are caused by a simple fact: the earth's axial tilt of 23.34° remains constant and in the same direction during the earth's entire orbit around the sun. In the northern hemisphere, the declination angle reaches its most northern and positive peak of 23.45° on June 21st (the summer solstice) and drops to its most southerly and negative peak of -23.45° on December 21st (the winter solstice).

Hour Angle

Depends on the momentary position of the earth in its axial rotation. Hour angle changes 15° every hour. The hour angle is measured from the local meridian, or the sun's highest point in the sky at solar noon (not necessarily 12:00 hours), with angles between sunrise and solar noon being positive and angles after noon being negative. The apparent motion of the sun is shown(Figure 3.1.3) for an observer at latitude 28° .

$$\text{Hour angle}(w_s) = (\text{True solar time} - 12)15^\circ \quad (3.2)$$

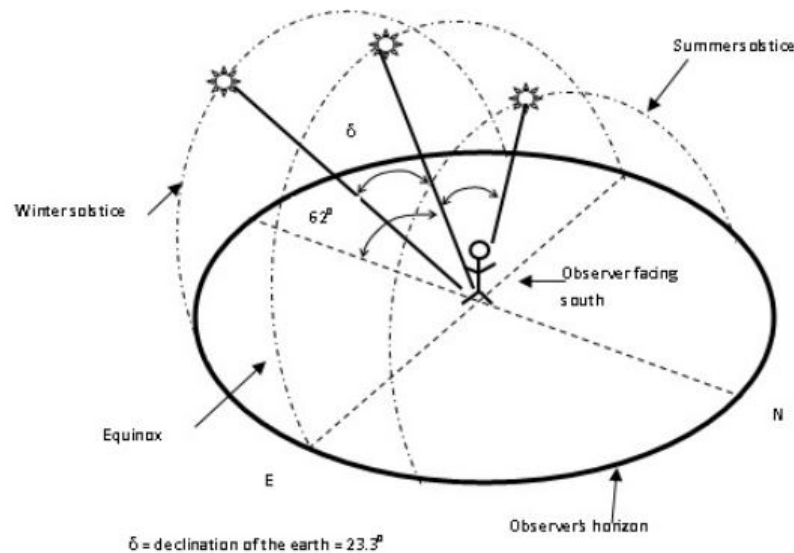
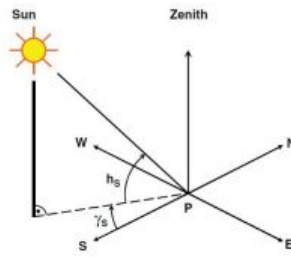

Figure 3.1.3: Apparent motion of Sun

When Latitude is ϕ , Declination angle δ and hour angle is w_s and solar altitude is h_s then(see Figure 3.1.4)

$$\sin h_s = \sin \phi \sin \delta + \cos \phi \cos \delta \cos w_s \quad (3.3)$$

$$\sin \gamma_s = \cos \delta \sin w_s / \cos h_s \quad (3.4)$$

Figure 3.1.4: Illustration of ϕ , δ , w_s and h_s

Also,

$$\frac{H_g}{H_o} = a + b \frac{S}{S_{max}} \quad (3.5)$$

Where, H_g = Monthly average of daily global radiation on horizontal surface.

H_o = Monthly average of daily global radiation on horizontal surface at same day.

S = Monthly measured average sunshine per day.

S_{max} = Monthly calculated average of day length and a and b are constant.

$$H_o = \frac{24}{\pi} I_{sc} \left(1 + 0.033 \cos\left(\frac{360n}{365}\right) (w_s \sin\phi \sin\delta + \cos\phi \cos\delta \sin w_s) \right) \quad (3.6)$$

Where, I_{sc} is solar constant (1368 W m^{-2})

w_s is Sunset hour angle

To obtain maximum solar radiation over the entire year in an area facing south (in northern hemisphere) tilt angle should be equal to the site's latitude. The optimal tilt angle of a PV array at any given time equals the latitude angle minus the declination angle. The declination angle changes throughout the year. It can be calculated by the Equation 3.7.

$$\text{Declination angle of sun } \delta = 23.45 \sin(360 \times (284 + N)/365) \quad (3.7)$$

Where, N is the day number in the year ($N=1$ for January 1 and $N=365$ for December 31).

Global Radiation

Global radiation is the sum of direct and diffuse solar radiation (i.e. aggregate radiation originating from the Sun) arriving at a level surface.

Global Irradiance

It is power density (power/area) of the global radiation arriving at a plane. Unit: W/m^2

Irradiation or Radiation energy(H)

Energy density (energy/area) of the global radiation arriving at a plane within a certain time interval, calculated by integration of irradiance G over this time interval. This can be one month (mt), one day (d) or one hour (h). Units: kWh/m^2 and MJ/m^2

Pyranometer

An instrument for measuring global radiation (global irradiance G) on a level surface over the whole wavelength range between approximately 0.3 and 3mm. Pyranometer is based on the thermoelectric principle and they are highly accurate but expensive instruments so that they are mainly used by weather services.

Reference cell

A calibrated solar cell for measuring global radiation on a level surface. They are much cheaper than pyranometers. They only utilize a portion of total incident insolation and is calibrated such that under

standard conditions (standard spectrum AM1.5, where $G = 1 \text{ kW/m}^2$). It exhibits the same insolation as a pyranometer. In practice there are discrepancies.

When solar radiation passes through the Earth's atmosphere it is attenuated by reflection, absorption and scatter. Irradiance in horizontal plane of the Earth's surface is weaker than extraterrestrial irradiance Global irradiance(G) on the horizontal plane of the Earth's surface for sunlight that passes through the Earth's atmosphere at 90 degree i.e. AM1 with clear skies is roughly 1 kW/m^2 . Global irradiance for solar radiation after traversing AM1.5 is still 835 W/m^2 . On a bright day with scattered clouds G can go as high as 1.3 KW/m^2 (a phenomenon known as cloud enhancement). Sunlight scatter in the Earth's atmosphere substantially attenuates direct sunlight, resulting in diffuse light that comes out of the sky from all directions. Solar radiation in some locations is diffuse for the most part.

3.1.2 Tracking System

Since, fixed structure modules do not get good exposure over daylight. So, mounting on tracking structure, have high power gains in total daily output of power(30% or greater can be achieved). Manual tracking along east-west axis is not practical as it has to be changed manually from east to west at fixed interval. Therefore this type tracking is generally automatic. Trackers can be motor driven or solar powered themselves.

One of solar powered design involves two tubes of Feron and oil on either side of the modules. Each tube is partially shaded by mask. As the sun moves, one tube becomes more exposed than the other. The Feron expands and either pushes a piston of transfers oil to the other side which causes the structure to move to follow the sun.

Motor driven trackers also use two light sensors on either side of the module. Depending upon the difference in the outputs of two sensors, the motor drives the structure in either direction to follow the sun.

Trackers can be

- Single axis follow the sun along only one axis(east-west) or
- Dual axis (east-west and tilt angle) for complete seasonal compensation.

Large PV systems have the modules on dual axis trackers, to maximize module output and minimize average costs. For small scale array/modules use of trackers is an economical issue. The gain provided by the tracker has always to be compared with the investment and maintenance cost of the tracker. However manual seasonal adjustment of tilt angle is advisable to all the PV installations.

Solar Time

Time based upon the apparent angular motion of sun across the sky with solar noon as the time the sun crosses the meridian. It does not coincide the local clock time. Two factors needed to obtain solar time from local time **a)**Constant correction to account the difference in longitude between observers meridian and the meridian in which the local time is based (eg. For Nepal Gaurishankar) **b)**Second Correction is the equation of time which takes into account of the earth rate of rotation which affect the time the sun crosses the meridian.

$$\text{Solar time} = \text{Standard time} + 4(L_{st} - L_{loc}) + E \quad (3.8)$$

Where, L_{st} = Longitude of Standard
 L_{loc} = Longitude of location



Figure 3.1.5: Movement of earth on its own axis.

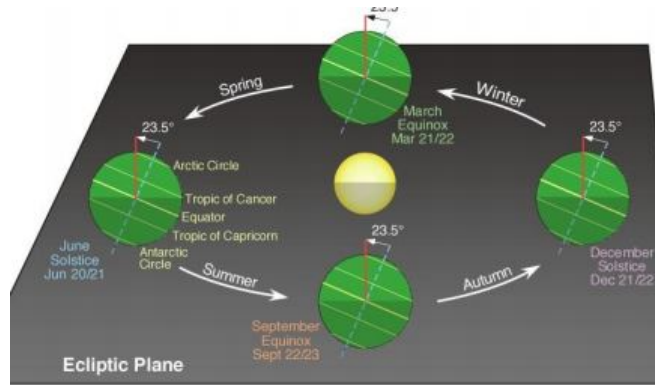

Figure 3.1.6: Movement of earth around sun.

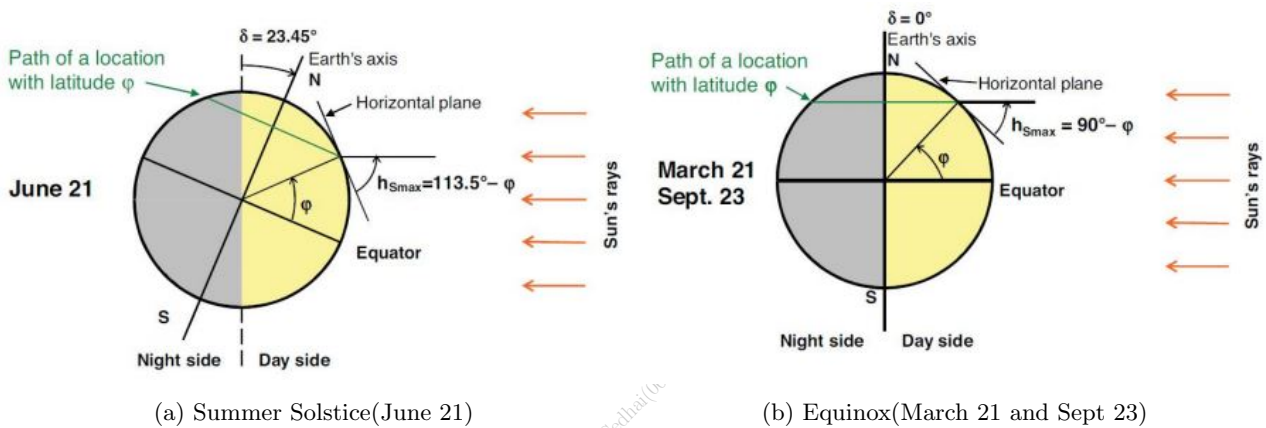

Figure 3.1.7: Summer solstice and equinox.

$E = \text{equation of time} = 9.87 \sin 2B - 7.53 \cos B + 1.5 \sin B$
 Where, $B = 360(n-81)/365$ and $n = \text{days of the year}$

3.1.3 Solar Thermal Energy(STE)

The basic purpose of solar thermal energy is to collect solar radiation and convert into useful solar energy. The performance of STE depends on factors like availability of solar energy, ambient air temperature and thermal characteristic of solar system itself.

When we trace the history of STE, we can find it was used from start of life for drying food and other things. On 500AD, Romans used mica and crude glass to trap the sun's heat at the same period Anasazi, Indian tribe of Colorado used south facing canyon wall to stay warm. In 1760 Horace de Saussure found room covered with glass gets hotter and in 1860 Auguste Mouchout work on "Hot Box" first solar powered motor, which involves a glass enclosed iron cauldron connected to a steam engine with copper tube.

In 1885, Charles Tellier, flat plate collector filled ammonia instead of water in his work as ammonia has lower boiling point. In 1875, William Adams arranged flat mirrors on the one and focused on blackened stationary boiler with the ability to rotate to follow the sun could run 2.5 HP steam engine. In 1880 John Ericsson developed parabolic trough. In 1906, Frank Shuman double insulated the collectors, added reflectors and a tracking device to achieve higher temp which is used for 55HP irrigation Pump.

Solar thermal system can be classified into two categories:

1. Passive solar thermal system: A passive system does not use a mechanical device to distribute solar heat. An example of a passive system for space heating is a sunspace or solar greenhouse on the south side of the house. Although passive systems are simpler, they may be impractical for a variety of reasons. They can be used for

- (a) Solar Home design

- i. Direct Gain-sunlight directly enters the space it is intended to heat, and is stored and released in that area.
 - ii. Indirect gain-TrombeWalls
 - iii. Isolated Gain-sun rooms
- (b) Heating
 - (c) Lighting
2. Active solar thermal system

3.1.4 Solar Thermal Collector

A collector designed to collect heat by absorbing sunlight, this term is generally applied to solar hot water panels but it can be generic term to denote more complex installations such as solar parabolic reflectors, solar trough and solar tower or simpler installations such as solar air heater. Complex collectors are used in solar power plants used to generate electricity by heating water to produce steam which drives a turbine connected to alternator. Collector types can be

Flat Plate Collector

They basically consist of dark plate absorber, a transparent cover that allows sunlight to pass through, heat transport fluid(e.g. air, water) to remove heat from absorber and heat insulated backing to avoid heat loss.

The absorber consists of a thin absorber sheet (of thermally stable polymers, aluminium, steel or copper, to which a matte black or selective coating is applied) often backed by a grid or coil of fluid tubing placed in an insulated casing with a glass or polycarbonate cover.

Heat coming to the absorber plate = $t\alpha I$

Heat Loss from the collector = $U \times (T_p T_a)$

Heat transfer rate to the fluid in the collector(m^{-2}) = $t\alpha I - U(T_p T_a)$

$$\text{Collector efficiency} = \frac{t\alpha I - U(T_p T_a)}{I} \quad (3.9)$$

Where, I = Solar Irradiance(Wm^{-2})

t =Transmitivity of Glass

α =Absorbility of Plate

T_p =Plate Temperature

T_a =Ambient Temperature

U = Overall Heat Loss Coefficient

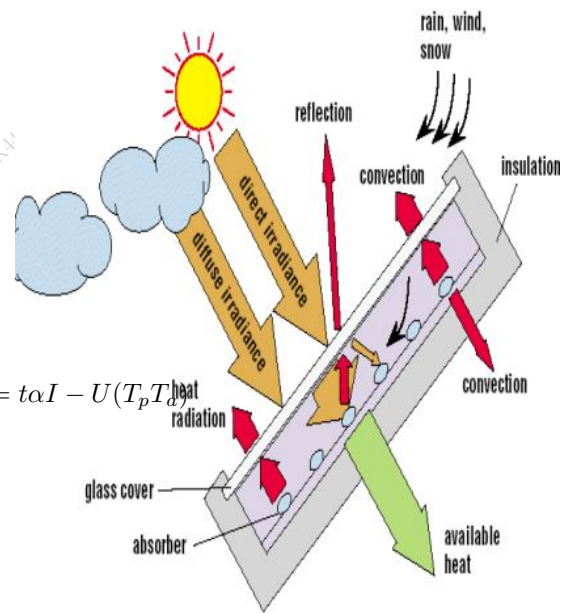

Figure 3.1.8: Flat plate collector.

Concentrated Collector

Concentrating, or focusing, collectors intercept direct radiation over a large area and focus it onto a small absorber area. These collectors can provide high temperatures more efficiently than flat-plate collectors, since the absorption surface area is much smaller.

Type of concentrating collector are

1. Parabolic trough system: These solar collectors use mirrored parabolic troughs to focus the sun's energy to a fluid-carrying receiver tube located at the focal point of a parabolic curved trough reflector. The energy from the sun sent to the tube heats oil flowing through the tube, and the heat energy is then used to generate electricity in a conventional steam generator.

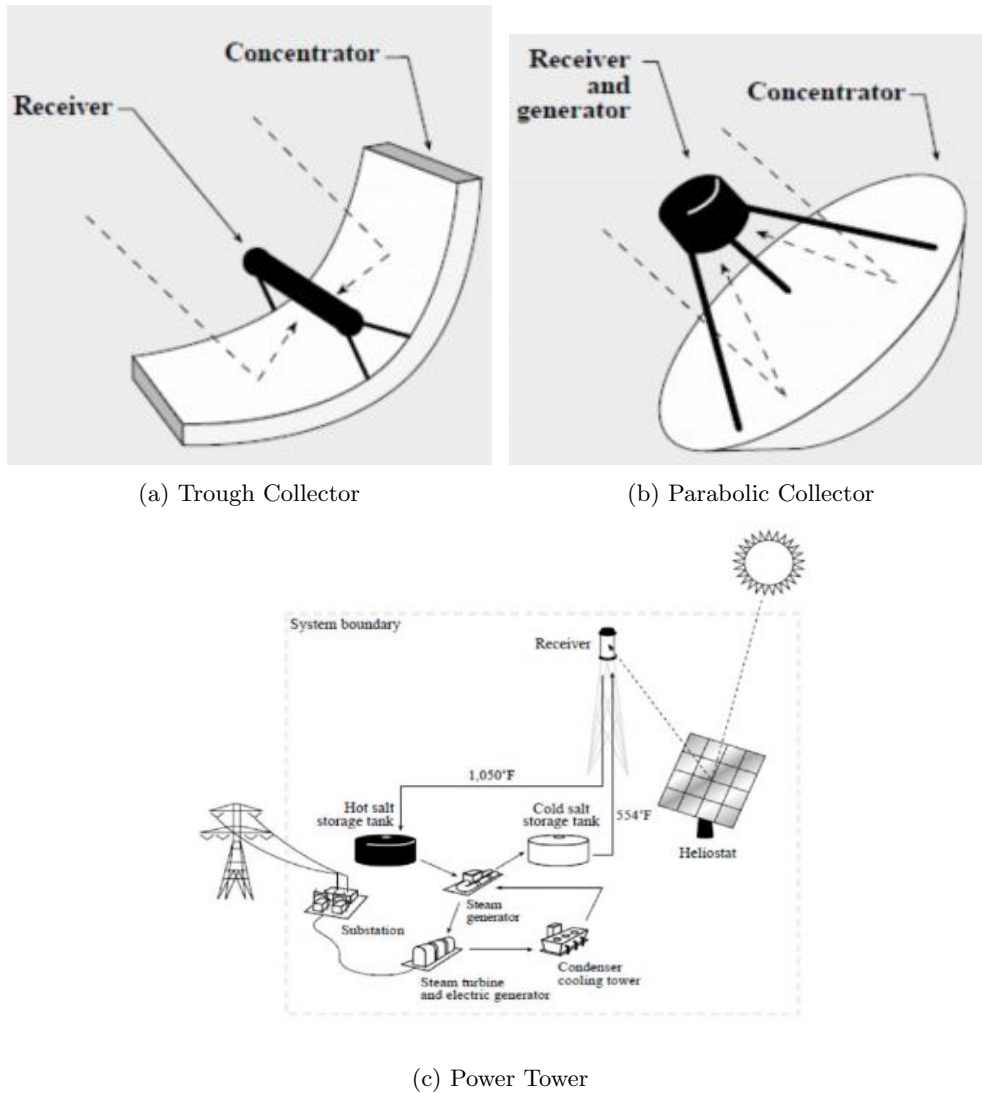

Figure 3.1.9: Concentrating collectors types.

Generally large parabolic trough power plants are "hybrids," meaning they use fossil fuels to supplement the solar output during periods of low solar radiation. They are all aligned along a north-south axis so they can track the sun from east to west during the day. Trough designs can incorporate thermal storage setting aside the heat transfer fluid in its hot phase-allowing for electricity generation several hours into the evening

2. Parabolic dish: The dish-shaped parabolic mirrors as reflectors are used to concentrate and focus the sun's rays onto a receiver, which is mounted above the dish at the dish center. Receiver absorbs the energy and transfers it to the engine. The ideal concentrator shape is parabolic, created either by a single reflective surface or multiple reflectors, or facets. A 250-kW plant composed of ten 25-kW dish/engine systems requires less than an acre of land.
3. Power tower: Central receivers (or power towers) use thousands of individual sun-tracking mirrors called "heliostats" to reflect solar energy onto a receiver located on top of a tall tower. The receiver collects the sun's heat in a heat transfer fluid (molten salt) that flows through the receiver. The salt's heat energy is then used to make steam to generate electricity in a conventional steam generator, located at the foot of the tower.
4. Stationary concentrating collectors:

3.1.5 Solar Water Heater(SWH)

It is the most common use of solar thermal technology for domestic water heating at low temperature (below 100°.

Only after the energy crisis of 1973 prospects of alternative energy including solar were came to priority.

In Nepal, a SWH was installed which was locally made at Department of Mines and Geology. Other report points out that the first prototype SWH was manufactured in 1968 by late Rev. B. R.Saubolle and Asha Brothers in Kathmandu. In 1974 Balaju Yantra Shala(BYS) constructed its first SWH using a old electric heater tank and self made collector. With some improvement BYS supplied to Buda Nilkantha Boarding school, which was the first public use of Solar thermal system in Nepal.

In its simplest form it is a piece of black plastic pipe, filled with water, and laid in the sun for the water to heat up. Simple solar water heaters usually comprise a series of pipes that are painted black, sitting inside an insulated box fronted with a glass panel(collector). The fluid to be heated passes through the collector and into a tank for storage. The fluid can be cycled through the tank several times to raise the heat of the fluid to the required temperature(Figure 3.1.10). Two common configurations are:

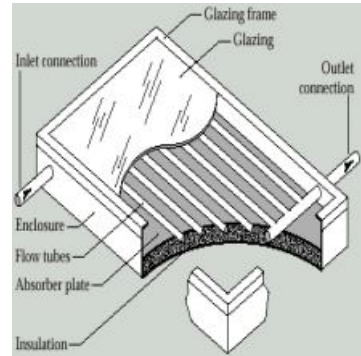

Figure 3.1.10: Solar water heater sectional view.

1. **Pumped solar water heaters:** Water is pumped to the collector using external means. The advantage is that the storage tank can be sited below the collector. The disadvantage of course

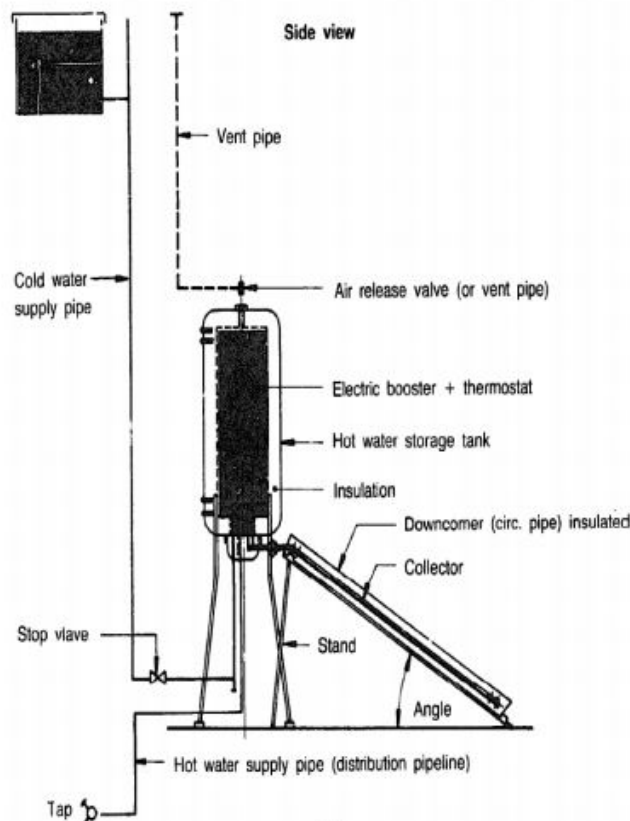

Figure 3.1.11: Thermosyphon solar water.

is that electricity is required to drive the pump. Often the fluid circulating in the collector will

be treated with an anti-corrosive and /or anti-freeze chemical. In this case, a heat exchanger is required to transfer the heat to the consumers hot water supply.

2. **Thermosyphon:** The thermosyphon uses the property hot water to rise above cold water. The tank placed above the top of the collector and as water is heated in the collector it rises and is replaced by cold water from the bottom of the tank. This cycle will continue until the temperature of the water in the tank is equal to that of the panel. Where there is a main water supply fresh cold water is fed into the system from the mains as hot water is drawn off for use(Figure 3.1.11).

A one-way valve is usually fitted in the system to prevent the reverse occurring at night when the temperature drops.

Open loop systems allow water to run through the solar panels and be stored in the storage tank to be used. Closed loop systems are where the water that circulates through the solar panel is separate from the water used. The system uses a heat exchanger. This means that anti freeze can be added to the water running through the panels which allows them to be used in cold climates.

Evacuated Tube Flat Plate Collector(ETC)

Heat loss to the environment inherent in flat plates is reduced as heat loss due to convection cannot cross a vacuum.

It forms an efficient isolation mechanism to keep heat inside the collector pipes. Typically, the water piping in an ETC is surrounded by two concentric tubes of glass with a vacuum in between that admits heat from the sun (to heat the pipe) but which limits heat loss back to the environment. The inner tube is coated with a thermal absorbent. Life of the vacuum varies from collector to collector, anywhere from 5 years to 15 years. It is customary to place a reflecting surface behind the array.

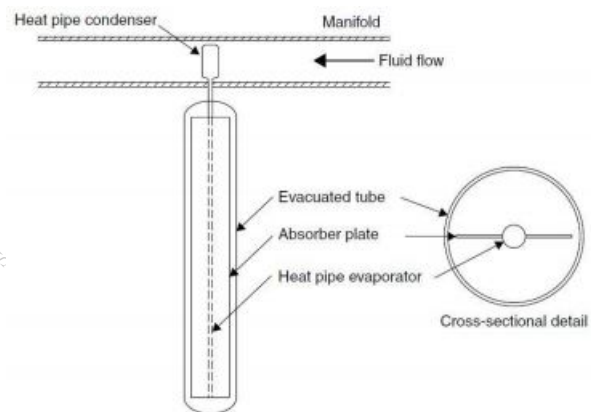

Figure 3.1.12: Evacuated tube flat plate Collector solar heater.

3.1.6 Solar Drier

A estimate showed that a minimum of 107 million tons of food were lost in 1976 out of 750 million tones produced including durable and perishables! About 50% of world's food and 36% of vegetables of the world are produced in developing countries where there is enormous food loss during post harvest period, due to spillage contamination, attack by birds, rodents and insects! Even conservation of 50% loss can make the developing countries self sufficient.

If the food is not dried the following may happen

1. Reduction in the germination rate of seed.
2. Discolouration, which reduces value of foods for many purposes.
3. Development of mustiness or other undesirable odours or flavours.
4. Chemical changes that render food undesirable or unfit for processing.
5. Production of toxic products, known as mycotoxins, some of which can be harmful if consumed.
6. Total spoilage and heating, which sometimes may continue to the point of spontaneous combustion.

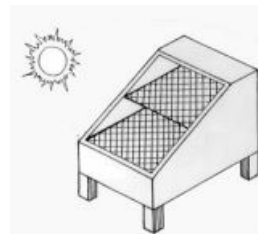

Figure 3.1.13: Cabinet solar drier.

How Drying Helps us?

1. Reduction of losses
2. Avoid biological and biochemical processes during storage
3. Prevents germination and growth of fungi and bacteria
4. Conservation of nutritional value and taste
5. Extension of life

Natural sun drying is simple and economic but there is no control over drying rate which can leads to crop overheating, discolouration, nutritional change. There will be no protection from rain, dust, birds also slow drying call back to no drying.

The advantages of controlled drying are control of temperature and humidity for drying which contributes to product quality, storage capability, hygiene improvement and reduction of wastage.

Drying is governed by the principle that for given place, for given amount of absolute humidity, relative humidity increases with decrease in temperature and vice-versa. Lower the relative humidity higher is the evaporative potential hence, as temperature increase, evaporation increase.

Types of solar drier.

1. Open Sun Drying
2. Controlled Drying
 - (a) Passive Mode(Natural Convection)
 - i. Direct
 - ii. Indirect
 - iii. Mixed
 - (b) Active Mode Forced Convection

3.1.7 Solar Cooker

Solar cookers are for cooking by Solar thermal power. They have two main categories: solar ovens and direct solar concentrators. **Solar oven** is basically a box with a glass cover. The box is lined with insulation and a reflective surface is applied to concentrate the heat onto the pots. The other approach is to reflect the suns rays onto a put, often with a parabolic dish. The pots can be painted black to help with heat absorption. Solar concentrators have parabolic like reflector surface focussing heat on focal point where food is kept for cooking.

3.1.8 Solar Thermal Power Plants

The idea is to use concentrating collectors to produce and supply steam to heat engines. This section is concerned with generation of mechanical and electrical energy from solar energy by processes based mainly on concentrating collectors and heat engines.

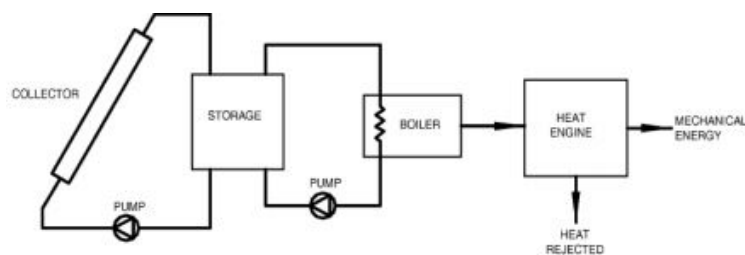

Figure 3.1.14: Block diagram of solar thermal power system plants.

3.1.9 Solar Photovoltaic(PV) Cells

Semiconductors like Silicon(Si), Germanium(Ge), Selenium(Se), Gallium arsenide(GaAs), gallium phosphide(GaP), Indium phosphide(InP), Cadmium Sulphide(CdS), Cadmium Telluride(CdTe) and Copper Indium diselenide(CuInSe₂ or CIS), have electrical conductivity between insulator and conductors and key parameter called band gap energy.

Silicon has four valence electrons in its outermost shell. In order to establish a stable electron configuration (rare-gas configuration with eight electrons or octet state), each silicon atom along with four adjacent atoms form a covalent bond, where each atom controls an electron at each bond; thus a bond consists of two electrons. In a silicon crystal, eight electrons are arrayed around each silicon atom, which means that the desired electron configuration has been attained.

Although semiconductor conductivity at temperatures above the absolute zero point is considerably higher than the conductivity of insulators, it is very low. This conductivity can be substantially increased by adding suitable external atoms in a process known as semiconductor doping. Doping is a process involving targeted semiconductor contamination that is carried out in a controlled manner.

Junction between p and n conducting semiconductors which automatically produces a space charge zone and thus creating electric field. Electrons are diffused into the p-zone from the n-zone, where they fill holes. The positively charged donor atoms left behind produce a positive space charge in the n-zone, while the now negatively charged acceptor atoms engender a negative space charge in the p-zone. These space charges create an electric field in the boundary.

Solar Cell is basically a large diode with a barrier layer that is exposed to light. For many light quanta(photon) to arrive at a point near the barrier layer, the (usually n-Si) semiconductor zone facing the light must be ultra thin(e.g. 0.5 mm). The photon with energy >EG can be absorbed, thus allowing for creation of an electron hole pair. The electric field E in the barrier layer quickly separates this electron hole pair before it can recombine. Since the charges have been separated, the space charge (and thus the electric field strength in the barrier layer) is reduced until it is no longer strong enough to separate electron hole pairs. It is at this point that the solar cell reaches its open-circuit voltage.

Ideally, the equivalent circuit consists of a light generated current source in parallel with the diode. In a little real scenario there is resistance in parallel and series. The series resistance (ideally zero) represents the resistance to current offered by the busbars, fingers, contacts and the cell's bulk semiconductor material. The parallel resistance relate to the non-ideal nature of the pn junction and impurities near the cell's edges that tend to provide a short circuit path around the junction.

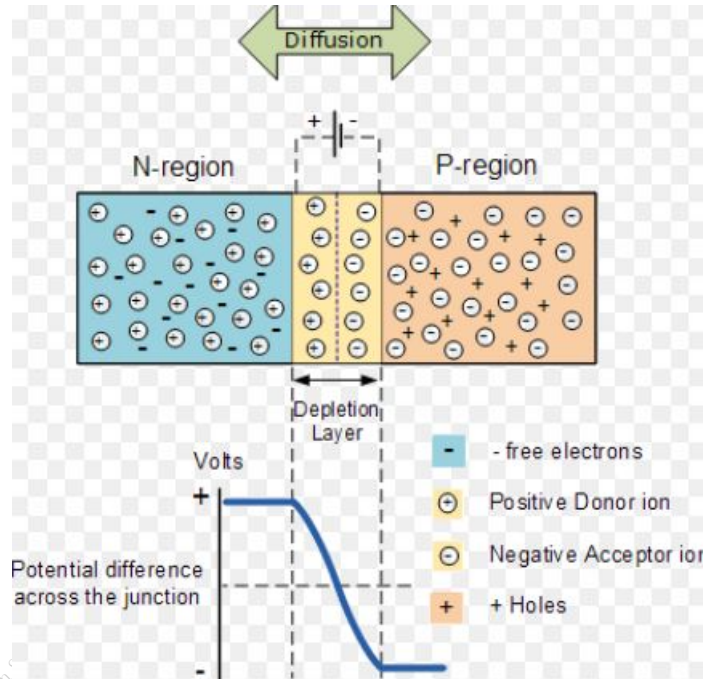

Figure 3.1.15: PN Junction.

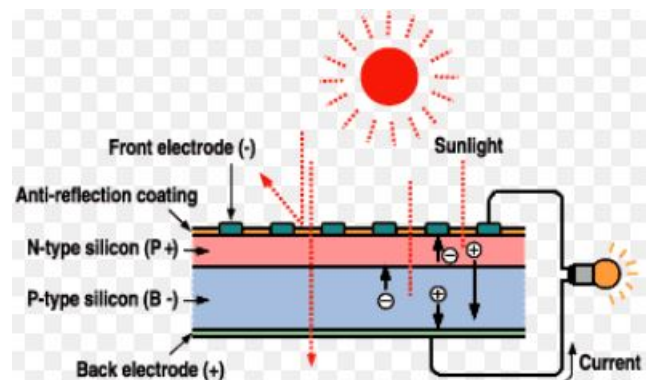

Figure 3.1.16: Solar cell structural section view.

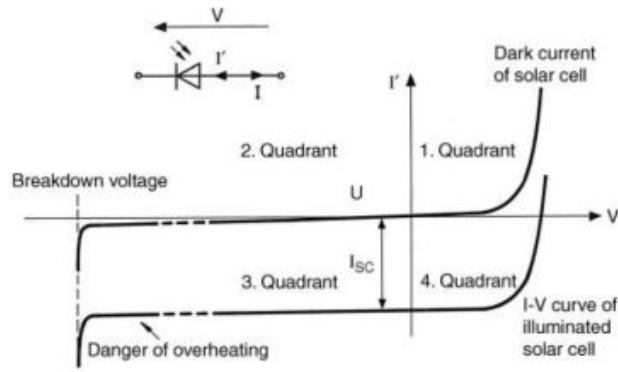
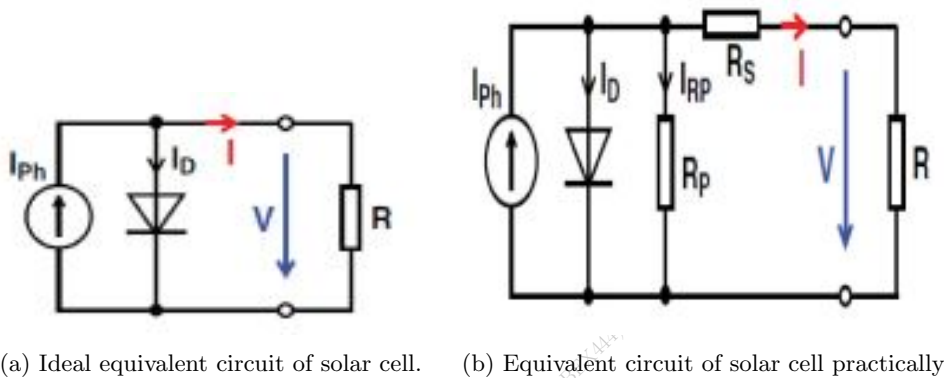

Figure 3.1.17: Solar cell, I-V characteristics.



(a) Ideal equivalent circuit of solar cell. (b) Equivalent circuit of solar cell practically

Figure 3.1.18: Concentrating collectors types.

Types of Solar Cell

1. **Monocrystalline:** Mono-Si also serves as photovoltaic, light-absorbing material in the manufacture of solar cells. It consists of silicon in which the crystal lattice of the entire solid is continuous, unbroken to its edges, and free of any grain boundaries. Mono-Si can be prepared intrinsic, consisting only of exceedingly pure silicon, or doped, containing very small quantities of other elements added to change its semiconducting properties. Monocrystalline silicon is used in the manufacturing of high performance solar cells. They are expensive, efficient, have uniform appearance. Lab efficiencies of 25.0 percent for mono-Si cells are the highest in the commercial PV market ahead of polysilicon with 20.4 percent and all established thin-film technologies namely, CIGS cells (19.8%), CdTe cells (19.6%), and a-Si cells (13.4%).
2. **Polycrystalline:** Polycrystalline silicon, also called polysilicon or poly-Si, is a high purity, polycrystalline form of silicon, used as a raw material by the solar photovoltaic and electronics industry. They are less expensive, have lower efficiency, appearance is not uniform in solar plate.
3. **Thin Film or Amorphous Solar Cell:** Amorphous silicon (a-Si) is a non-crystalline, allotropic form of silicon and the most well-developed thin film technology to-date. Thin-film silicon is an alternative to conventional wafer (or bulk) crystalline silicon. They have lower efficiency but have lower cost.

3.2 Hydro Power

Water constantly moves through a vast global cycle, in which it evaporates from lakes and oceans, forms clouds, precipitates as rain or snow, then flows back to the ocean. The energy of this water cycle, which is driven by the sun, it tapped most efficiently with hydropower. Hydropower plants capture the energy of falling water to generate electricity. The turbine converts the kinetic energy of falling water into mechanical energy. Then a generator converts the mechanical energy from the turbine into electrical energy.

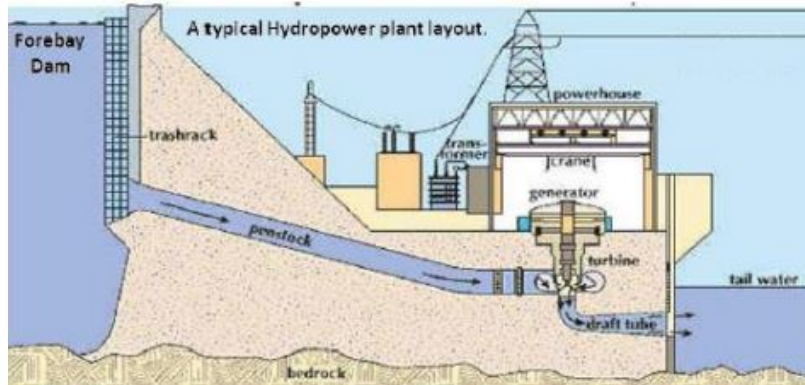

Figure 3.2.1: Hydropower general structure.

A dam blocks the water, holds it in a reservoir. Pipes called the penstock bring water from the reservoir to the powerhouse. The drop in elevation in the pen stock is call the "head." The force created is the force need to create electricity. Higher volume of water and a higher force of the head create a greater amount of energy. The powerhouse contain the turbines. The turbines move from the force of the head as it flows down the penstock. The rotating turbines turn a shaft that drives generators that produce electricity. Water not used for producing energy is released over the spill way of the dam.

$$\text{Power Potential}(P) = \frac{g\rho H_g Q_g}{1000} \quad (3.10)$$

Where, $g\rho$ = Weight density of water = $9810Nm^{-2}$

H_g = Level difference between intake and tailwater(m)

Q_s = Water flow rate at intake (m^3s^{-1})

There may be some losses in penstock, turbine, generator, canal, drive, transmission loss etc. Thus efficiency calculation should consider all these losses.

In terms of water usage hydropower may be of

1. **Run off River Type:** This uses water within the range of the natural river flow. Power output depends upon season as there is no storage of water in reservoir.
2. **Reservoir/Pondage Type:** They have reservoir, that enables regulating the river flow and can supply electricity according to demand also head may later according to water level in reservoir.
3. **Pump storage type:** It has an upper reservoir and lower reservoir. It generates power during peak demand and pumps up water during low demand, hence improves load factor.

3.2.1 Classification of Hydropower

In Terms of Capacity-Nepal's Context

SN	Name	Capacity(kW)
1	Pico Hydro	Upto 5kW
2	Micro Hydro	Upto 100kW
3	Mini Hydro	>100kW to 1000kW
4	Small Hydro	>1000kW to 10000kW
5	Medium Hydro	>10000kW to 50000kW
6	Large Hydro	>50000kW

Table 3.2.1: Classification of hydropower in terms of plant capacity in Nepal

In Terms of Available Head

1. Ultra Low Head : Below 3m

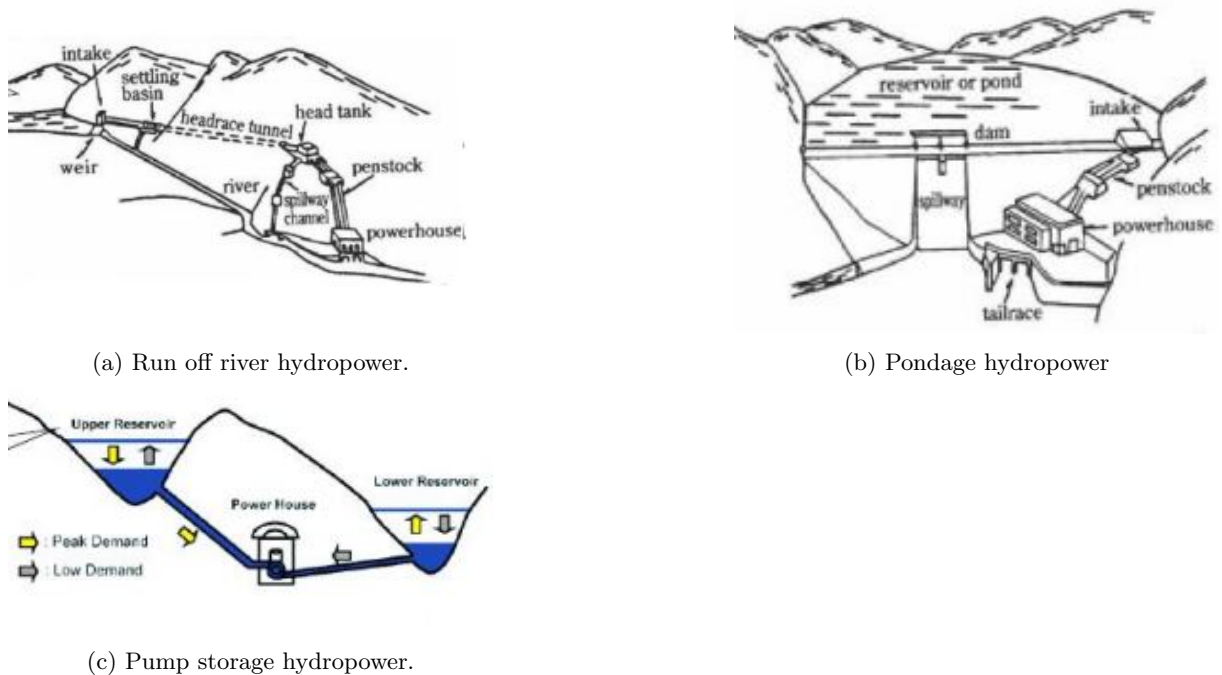

Figure 3.2.2: Hydropower types.

2. Low Head : Above 3m and upto 40m
3. High head : Above 40m

3.2.2 Water Turbines

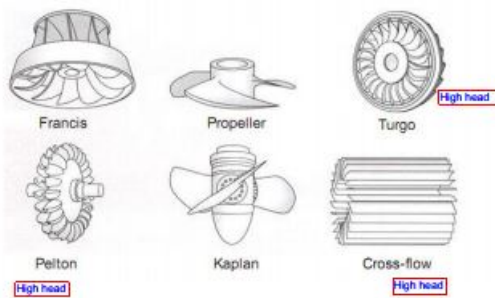

Figure 3.2.3: Types of turbine.

A hydraulic turbine is a roto-dynamic fluid machine, which converts hydraulic energy into mechanical energy. Turbine convert energy in the form of falling water into rotating shaft power. The turbine have runner with identical blades or bucket mounted on it, flow guide mechanism or nozzle to direct the flow at required level and outer casing(housing). They are of following types.

1. Impulse(High Head) turbines:
2. Reaction(Low Head) turbines:

In impulse turbine, pressure energy of water is completely converted into kinetic energy before hitting the turbine runner. There is no pressure difference between the inlet and outlet of turbine runner. In reaction turbine, there is pressure difference between inlet and outlet of turbine runner.

The energy transformed due to decrease in pressure energy or pressure difference is known as reaction effect(Table 3.2.2).

Pelton Turbine

It is impulse type turbine, normally use for medium to high head. It can be mounted horizontally and vertically. The multi jet pelton increase flow are used at medium head. At least one jet of water strike the buckets at atmospheric pressure, where maximum jet diameter should be about 1/3 of bucket width.

SN	Impulse Turbine	Reaction Turbine
1	High speed jet of water obtained from nozzle strike the runner bucket to rotate runner.	Runner to be completely filled with water and uses pressure drop across turbine runner.
2	It is easy to fabricate.	Difficult and expensive to fabricate.
3	It can tolerate sand.	Water should be clean.
4	It is suitable for medium to high head and also efficient for wide range of flow but have low specific speed.	It is suitable for low to medium head with poor part flow efficiency but with high specific speed.
5	There is no cavitation problem.	Cavitations must be avoided.

Table 3.2.2: Difference between Impulse and Reaction turbine.

The major site having pelton turbine are:

Kulekhani I	$30 \times 2\text{MW}$
Puwa Khola	$3 \times 2\text{MW}$
Sundarijal	$300 \times 2\text{KW}$
Pharping	$250 \times 2\text{KW}$
Khimti	$12 \times 5\text{KW}$
Chilime	$11 \times 2\text{MW}$
Aadhikhola	$1.7 \times 3\text{MW}$
Piluwa	$1.5 \times 2\text{MW}$

Turgo Turbine

It is an impulse turbine whose components are similar to the Pelton turbine. The only difference is that the jet strikes the plane of the runner on one side (usually at 20 degree) and exists on the other. In turgo turbine, water jet strikes simultaneously three vanes. Same as pelton turbine it can be installed horizontally and vertically but runner size are smaller than pelton turbine for same power output. They have higher specific speed and the discharged liquid do not interfere with incoming fluid. They can directly be connected to generator without intermediate costly speed increasing transmission.

Some disadvantages or negative aspects are the fabrications of runner and vanes are difficult because of their complex shape also vanes are more fragile than pelton buckets.

Crossflow Turbine

It is impulse turbine also known as Banki, Mitchell and ossberger turbine with drum shaped runner. The rectangular nozzle forms the jet, strikes full length of the runner. The flow of water can be increased with runner length and water strikes the blade twice. The partition valve allows part flow and a draught can increase the effective head. It can mounted horizontally. The reaction turbines considered are: Francis, Propeller and Kaplan Turbine.

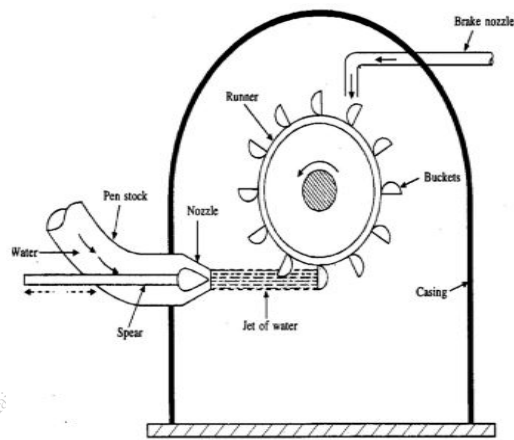

Figure 3.2.4: Pelton turbine.

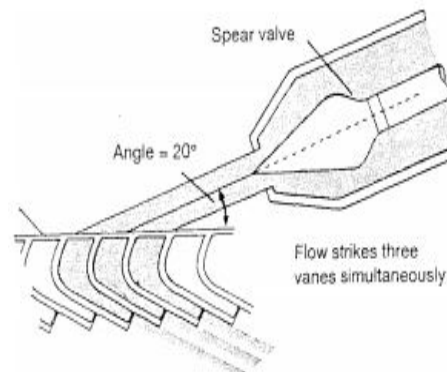

Figure 3.2.5: Turgo Turbine.

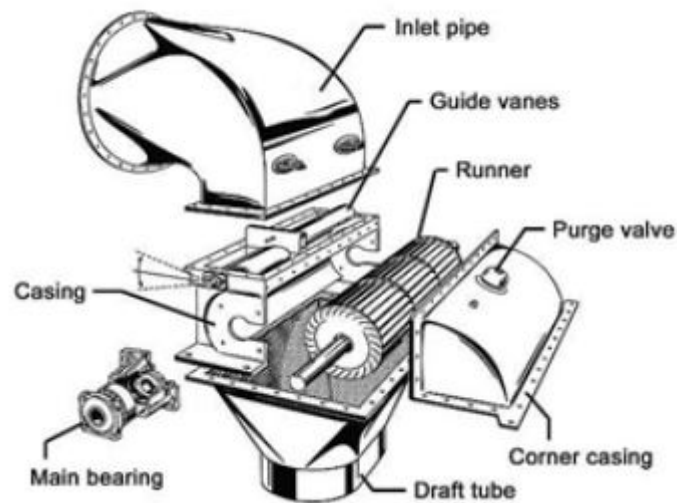

Figure 3.2.6: Crossflow Turbine.

Francis Turbine

A Francis turbine has a runner with fixed vanes, usually nine or more. The water enters the turbine in a radial direction with respect to the shaft, and is discharged in an axial direction. Water imparts most of its pressure energy to the runner and leaves via draught tube. Guide vanes are used to regulate the water flow and usually linked to governor. As the flow is reduced, the efficiency of the turbine drops off. Due to high installation cost and difficult in repair and maintenance, not preferable in micro-hydro.

There is a difference of pressure between the G/Vs and the runner which is called reaction pressure and is responsible for the motion of the runner. Water release from a draft tube submerged in water for easy release and reuse of exit water energy.

Propeller Turbine

Propeller turbine has high rotational speed than Francis turbine thus shaft (generally vertical) can be coupled without speed increasing device (gears). It is less expensive and easy to construct and suitable for repair and maintenance. It requires small generator and applicable for low head and high discharge.

Water enters the runner in the axial direction and leaves axially. The pressure at the inlet of the blade is larger than at the exit of the blades. Energy transfer is due to the reaction effect of pressure differences.

The main advantages are low cost, small contact and small number of blades thus less friction. Also Kaplan and propeller turbine can be mounted in any angular position but generally mounted in vertical position.

Disadvantages are less part load efficiency, absence of adjustable blades and loading on the blades are large due to few number of blades.

Kaplan Turbine

Prof. Kaplan (Germany, 1916) invented an adjustable blade propeller turbine. The Kaplan turbine is an axial-flow reaction water turbine that has adjustable blades. They are now widely used throughout the world in high-flow, low-head power production. It is equivalent to propeller turbine at full load. Its part

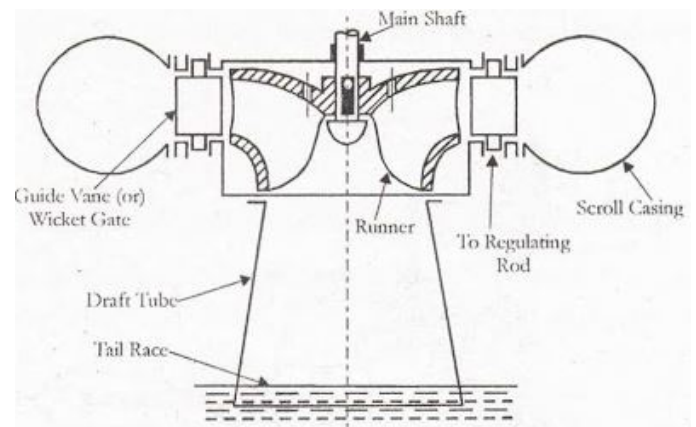
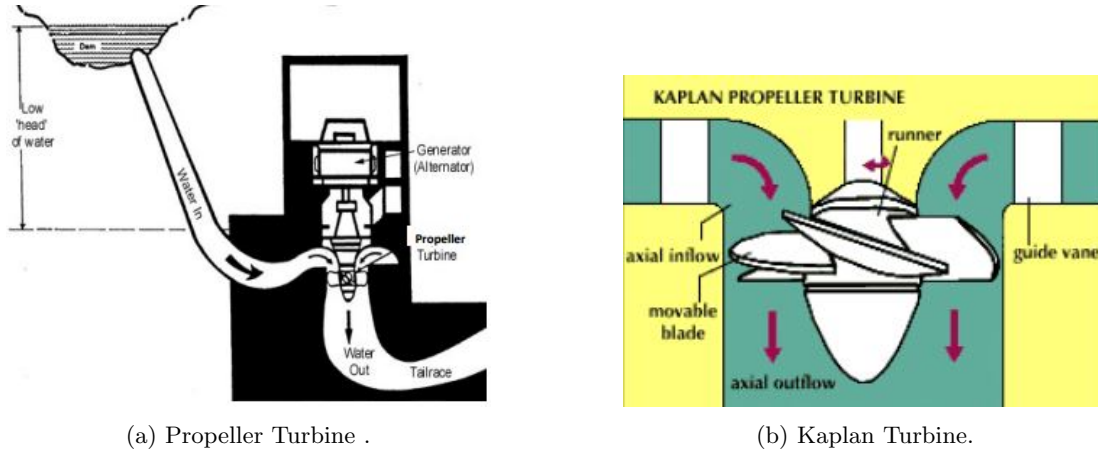

Figure 3.2.7: Francis Turbine.

load efficiency is good. In Kaplan turbine the runner blades are adjustable and can be rotated about pivots fixed to boss of the runner.

Advantage of Kaplan turbine are compact size for same power, good part load efficiency, low frictional loss and good efficiency for high flow and low head.

Disadvantages are large loading on blades due to few number of blades, not suitable for high head and low flow. It is very expensive to design, manufacture and install. There are cavitation problem.



(a) Propeller Turbine .

(b) Kaplan Turbine.

Figure 3.2.8: Propeller and Kaplan Turbines.

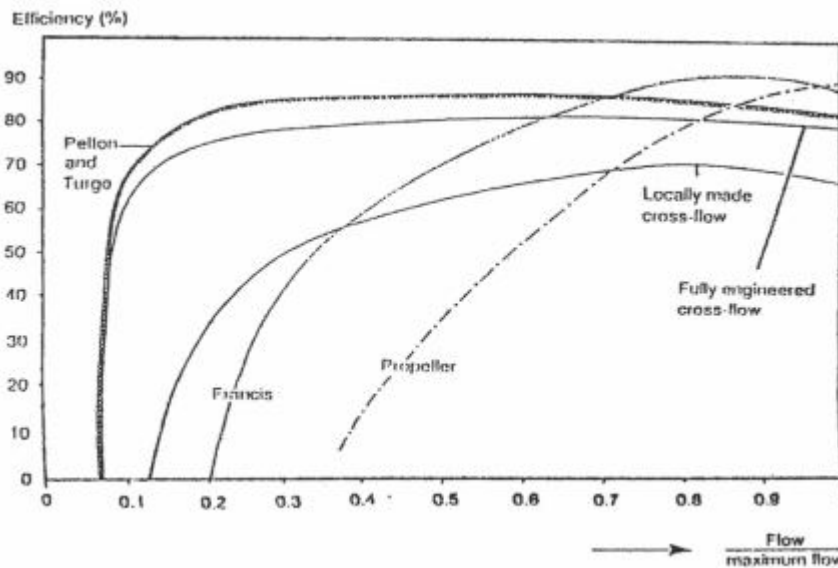

Figure 3.2.9: Turbine efficiency at different part flow conditions.

3.2.3 Importance of Micro Hydro Power Project: Nepal’s Context

It is renewable energy source and make use of locally available water resources with per KW cost very low compared to bigger power plants. Nepal has hilly and isolated settlement with abundance of water resources. Rural areas do not have national grid connection, thus such hydro power can be effective for electrification of rural and remote areas. Since hydropower is eco-friendly, this can lead to health improvement, sustainable development.

Some limitations are hydropower are site specific, long distance of transmission as houses are separated in remote areas and power demand is limited.

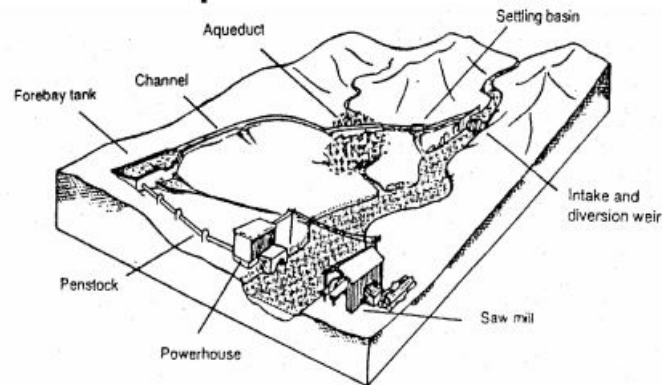

Figure 3.2.10: Major components of Micro Hydropower plant.

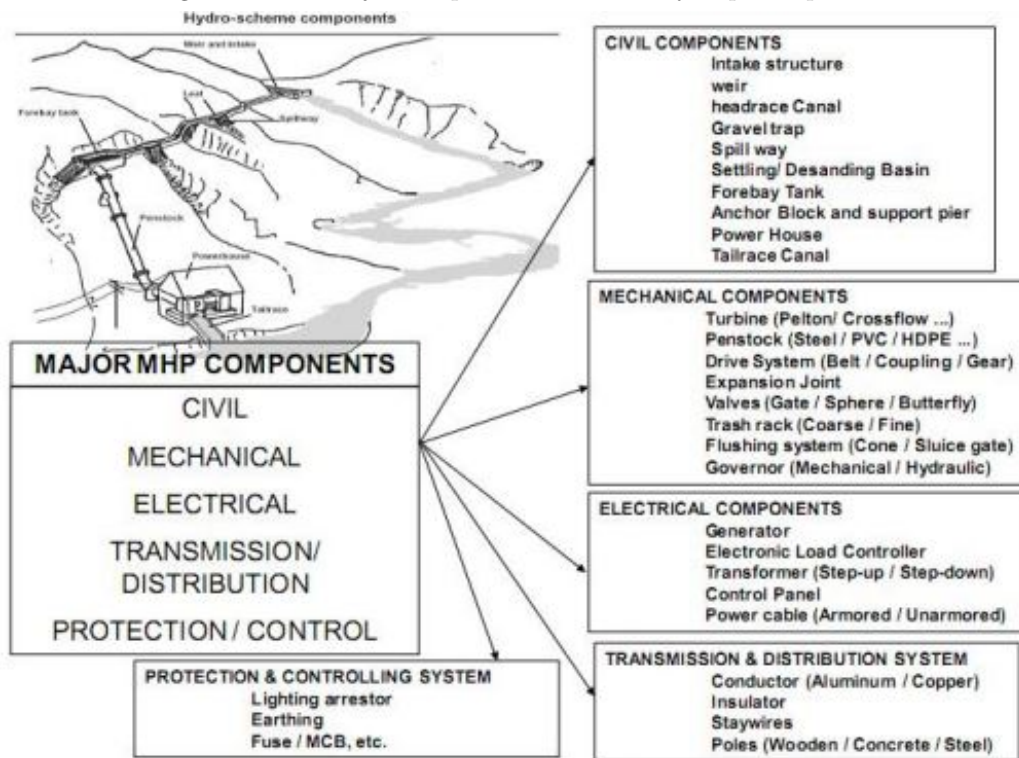

Figure 3.2.11: Major components of Micro Hydropower plant constructional wise.

3.3 Wind Energy

Wind is the movement of air caused by pressure differences within the atmosphere. This pressure differences exert a force that causes air masses to move from a region of high pressure to one of low pressure. That movement of air is referred as wind. Such pressure differences are caused primarily by uneven heating effects of the sun on the Earth's surface.

Since ancient times, people have harnessed the winds energy. Over 5,000 years ago, the ancient Egyptians used wind to sail ships on the Nile River. Later, people built windmills to grind wheat and other grains. The earliest known windmills were in Persia (Iran). As late as the 1920s, Americans used small windmills to generate electricity in rural areas without electric service. In the early 1980s wind energy really took off in California, partly because of state policies that encouraged renewable energy sources.

3.3.1 Wind Generation

Wind is simple air in motion. It is caused by the uneven heating of the earth's surface by the sun. Since the earth's surface is made of very different types of land and water, it absorbs the sun's heat at different

rates.

During the day, the air above the land heats up more quickly than the air over water. The warm air over the land expands and rises, and the heavier, cooler air rushes in to take its place, creating winds. At night, the winds are reversed because the air cools more rapidly overland than over water. In the same way, the large atmospheric winds that circle the earth are created because the land near the earth's equator is heated more by the sun than the land near the North and South Poles. Today, wind energy is mainly used to generate electricity. Wind is called a renewable energy source because the wind will blow as long as the sun shines.

The measurement of wind speeds is usually done using cup anemometer which has vertical axis and three cups which capture the wind and rotates. The number of revolutions per minute is registered electronically. Because of boundary layer effects at the earth's surface, the wind speed increases with altitude according to

$$\frac{v_1}{v_2} = \left(\frac{h_1}{h_2} \right)^a \quad (3.11)$$

Where, v_1 and v_2 are the wind speed at altitude h_1 and h_2 respectively, a is ground surface friction coefficient.

The first wind energy generator of 20KW capacity (10KW each) was installed in mountainous area of Nepal (Kagbeni) in 1989 as demonstration project. However, within the three month period, blade and tower of the wind generator were broken. The main reason reported was structural failure to withstand the gusty wind speed (source: WECS, 2002).

A wind turbine is a rotating machine which converts the kinetic energy in wind into mechanical energy. If the mechanical energy is used directly by machinery, such as a pump or grinding stones, the machine is usually called a windmill but if converted to electricity, the machine is called a wind generator, wind turbine, wind power unit etc.

The wind power can be calculated as

$$P_{wind} = \frac{1}{2} \rho A V_{av}^3 \quad (3.12)$$

$$\text{Power from a Wind Turbine Rotor} = C_p \frac{1}{2} \rho A V_{av}^3 \quad (3.13)$$

Where, P_{wind} = the specific wind power

V_{av} = The average wind speed (m/s)

A = Wind rotor cross sectional area (m²)

$\rho = \frac{p}{RT}$, p is air pressure (Pa), R is the specific gas constant (287 J K g⁻¹ K⁻¹).

C_p = power coefficient, percentage of power in the wind that is converted into mechanical energy.

Wind Turbines may be of following types according to the axis of rotation of blades.

1. Horizontal axis wind turbine (HAWT): The rotor axis is kept horizontal and aligned parallel in the direction of the wind stream.
2. Vertical axis wind turbine (VAWT): The rotor axis is vertical and fixed, and remains perpendicular to the wind stream.

Main Components of Wind Turbine

1. Hub : Rotors attached to low speed shaft

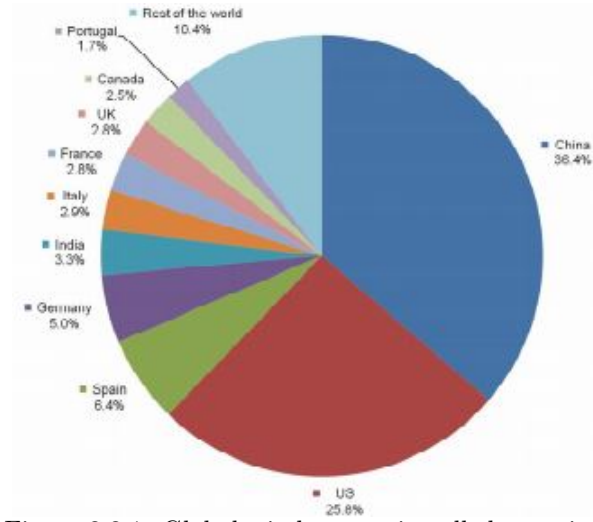

Figure 3.3.1: Global wind energy installed capacity.

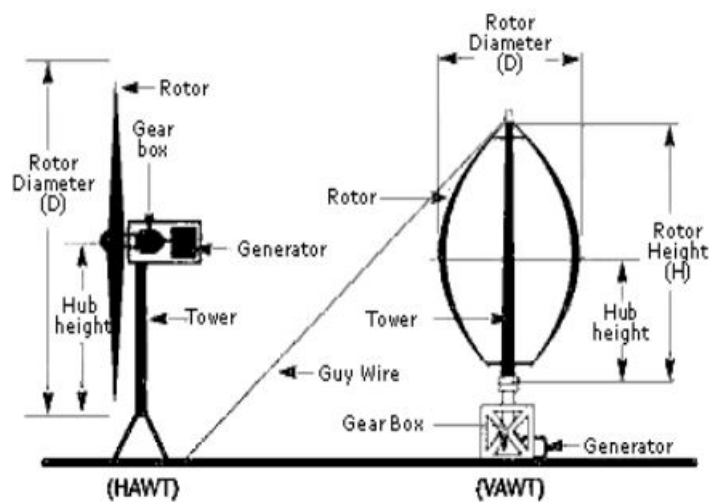

Figure 3.3.2: Types of wind turbines.

2. Gearbox : Needed to increase rotational speed ratio to that required by generator, 20-50 rpm to 1000-1500 rpm
3. Clutch :Used to engage/disengage gear box to generator
4. Brakes : Used in emergency/maintenance periods
5. Yaw drive mechanism : Operated by the electronic controller which senses the wind direction using the wind vane, Normally, the turbine will yaw only a few degrees at a time, when the wind changes its direction
6. Cooling Unit: Cooling needed for generator may be air or liquid cooled
7. Tower: Tubular or lattice

Control Systems in Wind Turbine

The main purpose of wind turbine control systems is to manage the safe, automatic, continuous operation of the turbine. This reduces operating costs, provides consistent dynamic response and improved product quality and helps to ensure safety. This operation is usually designed to maximize annual energy capture from the wind while minimizing turbine loads.

Control systems are typically divided, functionally, if not physically, into three separate parts: (1) a controller that controls numerous wind turbines in a wind farm, (2) a supervisory controller for each individual turbine and, (3) if necessary, separate dynamic controllers for various turbine subsystems in each turbine. These separate controllers operate hierarchically with interlocking control loops.

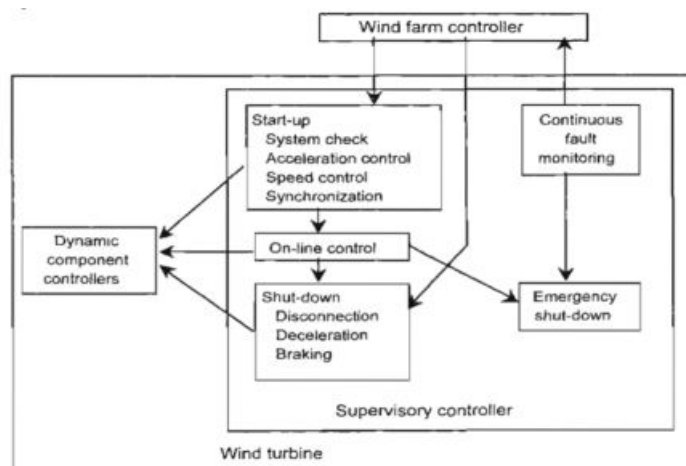

Figure 3.3.3: Wind turbine control systems.

The supervisory controller switches between turbine operating states (power production, low wind shutdown, etc.), monitors wind and fault conditions such as high loads and limit conditions, starts and stops the turbine in an orderly fashion, and provides control inputs to the turbine dynamic controllers, for example, the desired speed ratio or rpm.

In contrast, dynamic controllers for various turbine components make continuous high speed adjustments to turbine actuators and components as they react to high speed changes in operating conditions. It is used to control systems in which larger system dynamics affect the outcome of control actions. Dynamic controller will manage only specific subsystem of the turbine, leaving control of other subsystems to other dynamic controllers and coordination of various dynamic controllers and other operations to supervisory control systems. They are used to adjust blade pitch to reduce drive train torques, to control power flow in a power electronic converter or to control the position of actuator.

Wind Farms

A wind farm or wind park is a group of wind turbines in the same location used to produce electricity. A large wind farm may consist of several hundred individual wind turbines and cover an extended area of hundreds of square miles, but the land between the turbines may be used for agricultural or other purposes. Many of the largest operational onshore wind farms are located in China and the United States. For example, the largest wind farm in the world, Gansu Wind Farm in China has a capacity of over 6,000 MW of power in 2012 with a goal of 20,000 MW by 2020. The Alta Wind Energy Center in California, United States is the largest onshore wind farm outside of China, with a capacity of 1,020 MW.

As a general rule, economic wind generators require wind speed of 16 km/h (10 mph) or greater to construct wind farm. An ideal location would have a near constant flow of non-turbulent wind throughout the year, with a minimum likelihood of sudden powerful bursts of wind. An important factor of turbine siting is also access to local demand or transmission capacity.

Individual turbines are interconnected with a medium voltage (usually 34.5 kV) power collection system and communications network. At a substation, this medium-voltage electrical current is increased in voltage with a transformer for connection to the high voltage transmission system. Construction of a land-based wind farm requires installation of the collector system and substation, and possibly access roads to each turbine site.

3.3.2 Advantages of Wind Energy

1. The wind is free and with modern technology it can be captured efficiently.
2. Once the wind turbine is built the energy it produces does not cause green house gases or other pollutants.
3. Although wind turbines can be very tall each takes up only a small plot of land. This means that the land below can still be used. This is especially the case in agricultural areas as farming can still continue.
4. Many people find wind farms an interesting feature of the landscape.
5. Remote areas that are not connected to the electricity power grid can use wind turbines to produce their own supply.
6. Wind turbines have a role to play in both the developed and third world.
7. Wind turbines are available in a range of sizes which means a vast range of people and businesses can use them. Single households to small towns and villages can make good use of range of wind turbines available today.

3.3.3 Disadvantages of Wind Energy

1. The strength of the wind is not constant and it varies from zero to storm force. This means that wind turbines do not produce the same amount of electricity all the time. There will be times when they produce no electricity at all.
2. Many people feel that the countryside should be left untouched, without these large structures being built. The landscape should be left in its natural form for everyone to enjoy.

3. Wind turbines are noisy. Each one can generate the same level of noise as a family car travelling at 70 mph.
4. Birds and bats are affected if wind farm or turbine are constructed on their way.
5. When wind turbines are being manufactured some pollution is produced. Therefore wind power does produce some pollution.
6. Large wind farms are needed to provide entire communities with enough electricity.

3.4 Geothermal Energy

Geothermal energy is the heat from the Earth. It's clean and sustainable. Resources of geothermal energy range from the shallow ground to hot water and hot rock found a few miles beneath the Earth's surface, and down even deeper to the extremely high temperatures of molten rock called magma. Almost everywhere, the shallow ground or upper 10 feet of the Earth's surface maintains a nearly constant temperature between 50 and 60F (10 and 16C).

Geothermal waters are broadly classified into

- High-temperature (above 150°): It can be used for electricity generation.
- Low-temperature (20° to 150°): Low temperature geothermal energy can be used for direct heating for residential, industrial and commercial applications.

Geothermal Reservoir/Resources

1. Hydro thermal Convective System
 - (a) Hot Water fields
 - (b) Wet steam field
 - (c) Dry steam field
2. Geo-pressured resources
3. Hot Dry Rock(HDR) resource
4. Magma resource.

Geothermal Plant Technologies

Three power plant technologies are being used to convert hydrothermal fluids to produce electricity:

1. Dry steam plants:
2. Flashed steam plants:
3. Binary cycle plants:

3.4.1 Geothermal Heat Pumps

A geothermal heat pump or ground source heat pump (GSHP) is a central heating and/or cooling system that transfers heat to or from the ground.

It uses the earth as a heat source (in the winter) or a heat sink (in the summer). This design takes advantage of the moderate temperatures in the ground to boost efficiency and reduce the operational costs of heating and cooling systems, and may be combined with solar heating to form a geosolar system with even greater efficiency.

Setup costs are higher than for conventional systems, but the difference is usually returned in energy savings in 3 to 10 years, and even shorter lengths of time with federal, state and utility tax credits and incentives. Geothermal heat pump systems are reasonably warranted by manufacturers, and their working life is estimated at 25 years for inside components and 50+ years for the ground loop.

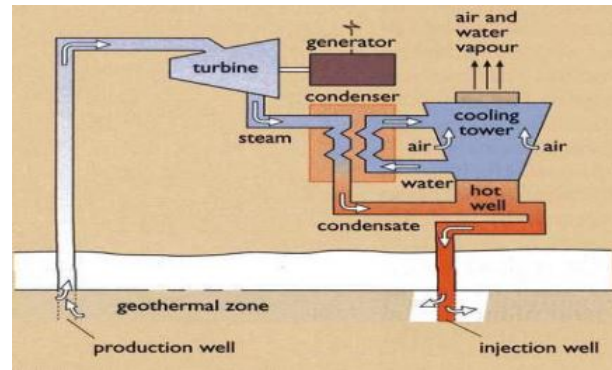

Figure 3.4.1: Dry steam geothermal plant.

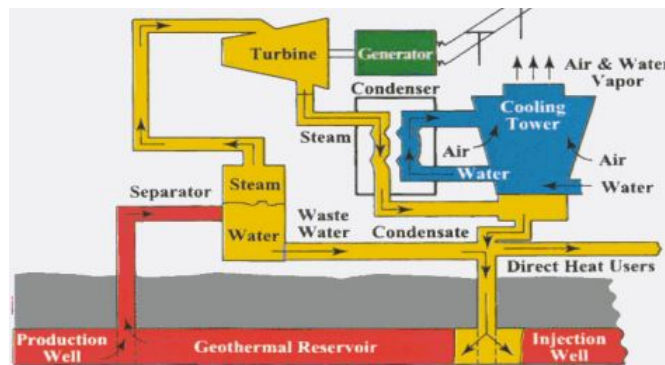

Figure 3.4.2: Flashed steam geothermal plant.

3.4.2 Advantages and Disadvantages of Geothermal Energy

Some advantages are:

1. First and foremost, geothermal energy is renewable, meaning that as long as we don't pump too much cold water into the earth -cooling off the hot rocks- the energy will just keep on coming!
2. Secondly, geothermal energy doesn't produce pollution, and at the same time, it doesn't contribute to the greenhouse effect!
3. The power stations for geothermal energy don't take up a whole bunch of room, and because of this, they tend to have less of an impact on the surrounding environment.
4. Because geothermal energy is energy in and of itself, no outside sources of fuel are needed to keep the power houses running.
5. And, even better, geothermal efficiency offers an even more exciting benefit to the frugal home owner - once you've built the geothermal power station, the energy is nearly, well, free! While it may require a little energy to actually run the pump, you can tap into the energy that is already being produced to handle this task.
6. Geothermal power plants provide steady state and predictable baseload power.
7. They are reliable and work for 98% of time.

Some disadvantages are:

1. Many of the best potential resources are located in remote or rural areas, often on federal or state lands.
2. Developing projects on federal or state lands can be a challenge. The leasing process can be very cumbersome, especially when a project might conflict with other land uses.

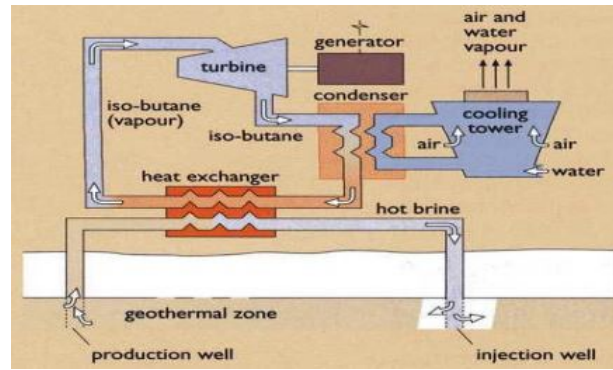

Figure 3.4.3: Binary cycle geothermal plant.

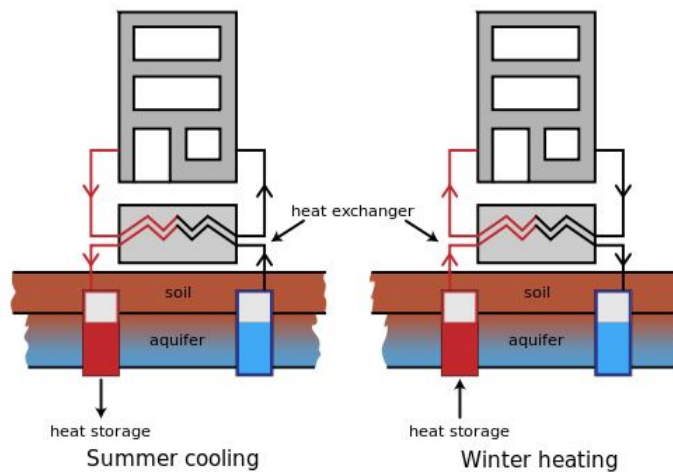

Figure 3.4.4: Geothermal heat pump during summer and winter.

3. Although cost have decreased in recent years, exploration and drilling for power production remain expensive.
4. Using best geothermal resources for electricity production may require an expansion or upgrade of the transmission system.
5. The success rate for discovering geothermal resources in new, untapped areas is approximately 20%. In areas where wells already are producing, the chance of locating more wells increases to about 80%.
6. The productivity of geothermal wells decline over time. As a result, it is crucial that developers manage the geothermal resource efficiently.
7. Dense fog on local atmosphere, radio active material escaping.

3.4.3 Applications

1. Generation of electric power
2. Industrial Process heat
3. Food processing
4. Space heating for building
5. Bathing facilities

3.4.4 Geothermal Energy in Nepal

Efforts were made in Nepal during 1980-1986 to investigate the geothermal springs. Identified about more than 28 geothermal springs in different parts of Nepal. Total potential of geothermal energy resource is not yet known in Nepal. Many of thermal springs are located on the northern colder parts where access to hydroelectricity is very rare. Preliminary study results; subsurface temperatures, of geothermal are in the range of 85 to 115°C.

These temperatures below 150°C is unsuitable for electricity generation. But low temperature water can be used for a number of economic activities. e.g. fish farming, swimming pools, bio-degradation of waste, fermentation, mushroom growing, animal husbandry, greenhouses, irrigation, space heating, drying of stock fish, vegetables, and various farm products and other purposes-soil warming, and space heating. But all these application are to be popularized yet in Nepal.



Figure 3.4.5: Geothermal location of Nepal.

Use of geothermal spring water is confined to bathing and therapeutic purposes in Nepal. Bhurung tatopani of Myagdi is extensively used for bathing as it is known long for its healing properties. High sulphur containing tatopani's (hot water) are in Dokhola (Myagdi), Hatiya (Sankhuwasabha), Kodari (Sindhupalchowk), etc.

3.5 Biomass and Bioenergy

The word *Biomass* is a very comprehensive term comprising of all forms of matter derived from biological activities and are present either on the surface of the soil or at different depths of water, lakes, streams, river, seas, ocean etc. The material of plants and animal is called biomass. It is organic carbon based material that reacts with oxygen in combustion and natural metabolic processes to release heat. The initial material may be transformed by chemical and biological processes to produce intermediate biofuels, such as methane gas, ethanol liquid or charcoal solid. The initial energy of biomass-oxygen system is captured from solar radiation in photosynthesis process.

Biomass production varies with local conditions, and is about twice as greater per unit surface area on land than at sea. The industrial use of biomass energy may be large (e.g. sugar-cane). The domestic use of biofuel in wood, dung and plant residues for cooking of prime importance for about 50% of the world's population. Around 43% of the energy used by the third world country is derived from biomass. Nearly, 2.4 billion people are totally reliant on biomass fuels for their energy needs. During photosynthesis, the Sun's energy converts water and carbon dioxide into organic matter. Yet only 14% of the world's energy comes from biomass. If biomass is to be considered renewable, growth must at least keep pace with use. It is disastrous that forest and firewood consumption is significantly outpacing growth in ever increasing areas of the world.

3.5.1 Types Of Biomass

1. Forest waste saw dust, leaves, twigs, Shrubs, residues of herbs and herbal products
2. Agricultural residues -rice husk, rice straw, rice bran, wheat husk, wheat straw, wheat bran, maize cobs, maize stalks, sugarcane leaves,

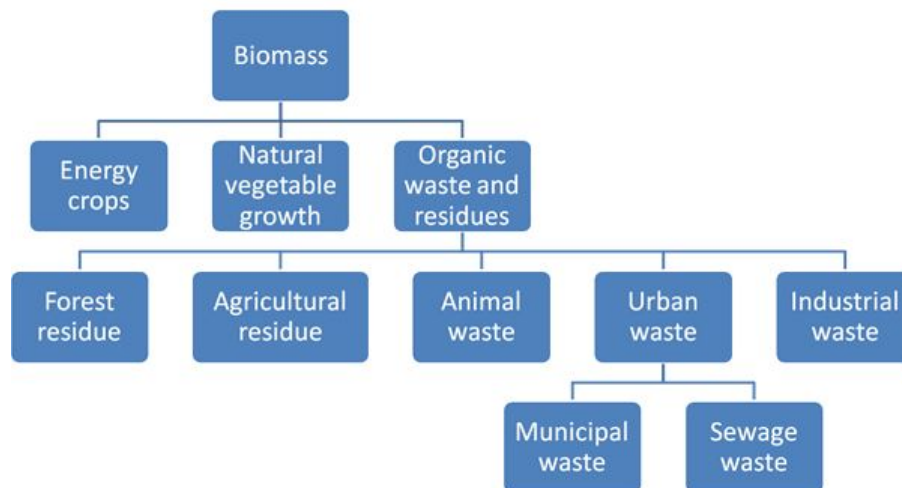

Figure 3.5.1: Biomass Classification

3. Industrial waste/residues - sugarcane baggasse, coffee husk, tobacco waste, tea waste Herbal residues

3.5.2 Conversion of Biomass to Biofuel

A biofuel is a type of fuel whose energy is derived from biological carbon fixation. Biofuels include fuels derived from biomass conversion, as well as solid biomass, liquid fuels and various biogases Biofuels are gaining increased public and scientific attention, driven by factors such as oil price hikes and the need for increased energy security.

Bioethanol is an alcohol made by fermentation, mostly from carbohydrates produced in sugar or starch crops such as corn or sugarcane. Cellulosic biomass, derived from non-food sources, such as trees and grasses, is also being developed as a feedstock for ethanol production. Ethanol can be used as a fuel for vehicles in its pure form, but it is usually used as a gasoline additive to increase octane and improve vehicle emissions. Bioethanol is widely used in the USA and in Brazil

Biodiesel is made from vegetable oils and animal fats. Biodiesel can be used as a fuel for vehicles in its pure form, but it is usually used as a diesel additive to reduce levels of particulates, carbon monoxide, and hydrocarbons from diesel powered vehicles. Biodiesel is produced from oils or fats using trans-esterification and is the most common biofuel in Europe.

Most transportation fuels are liquids, because vehicles usually require high energy density, as occurs in liquids and solids. High power density can be provided most inexpensively by an internal combustion engine; these engines require clean-burning fuels, to keep the engine clean and minimize air pollution.

The fuels that are easiest to burn cleanly are typically liquids and gases. Thus, liquids (and gases that can be stored in liquid form) meet the requirements of being both portable and clean-burning. Also, liquids and gases can be pumped, which means handling is easily mechanized, and thus less laborious. There are basically four major routes for the conversion of biomass to energy and other useful products.

1. Thermo Chemical Conversion process

- (a) Direct Combustion: Direct combustion for immediate heat. Dry homogeneous input is preferred.
- (b) Pyrolysis: This is general term for all processes whereby organic material is heated or partially combusted to produce secondary fuels and chemical products. The input may be wood, biomass residues, municipal waste. It is a physical and chemical decomposition of organic matter brought about by heating in the absence of air. The products of pyrolysis are char, liquid distillates and gas .
- (c) Gasification: It is a process in which solid fuels are broken down by the use of heat with a restricted supply of air to produce combustible gases which can be used as a fuel for internal combustion engines. The gas known as produce gas is a mixture of : CO - 15-29%, H_2 - 5-15%, CO_2 - 5-15%, N_2 - 50-65%, CH_4 - few %
- (d) Liquefaction: It is a high temp and high pressure catalytic process, which converts biomass to fuel oil.

2. Bio-chemical Conversion Process

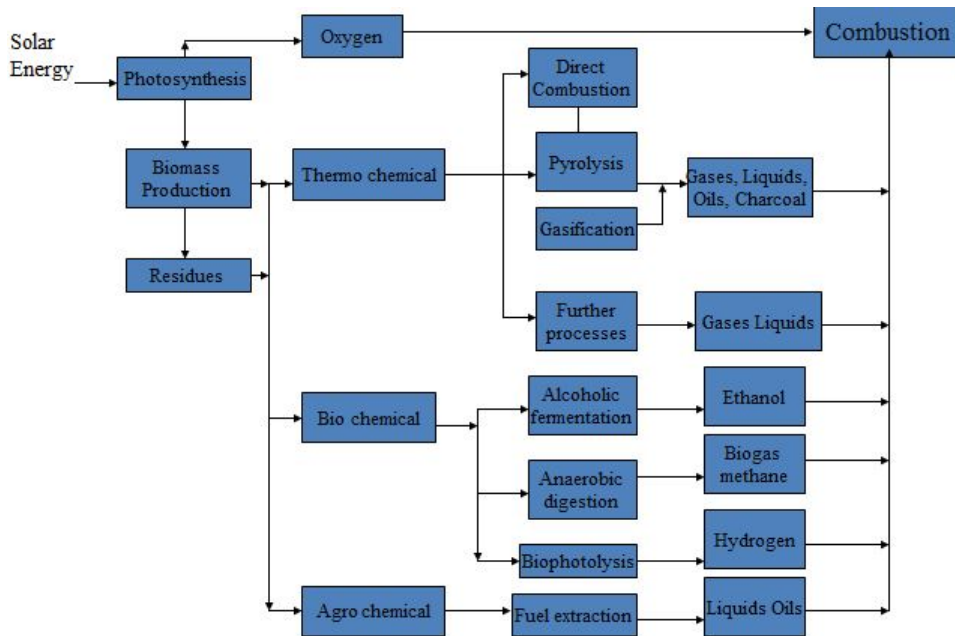

Figure 3.5.2: Biomass Conversion Process

- (a) Alcoholic fermentation: Ethanol is a volatile liquid fuel that may be used in place of refined petroleum. It is manufactured by the action of micro-organisms and is therefore a fermentation process. Conventional fermentation has sugars as feedstock.

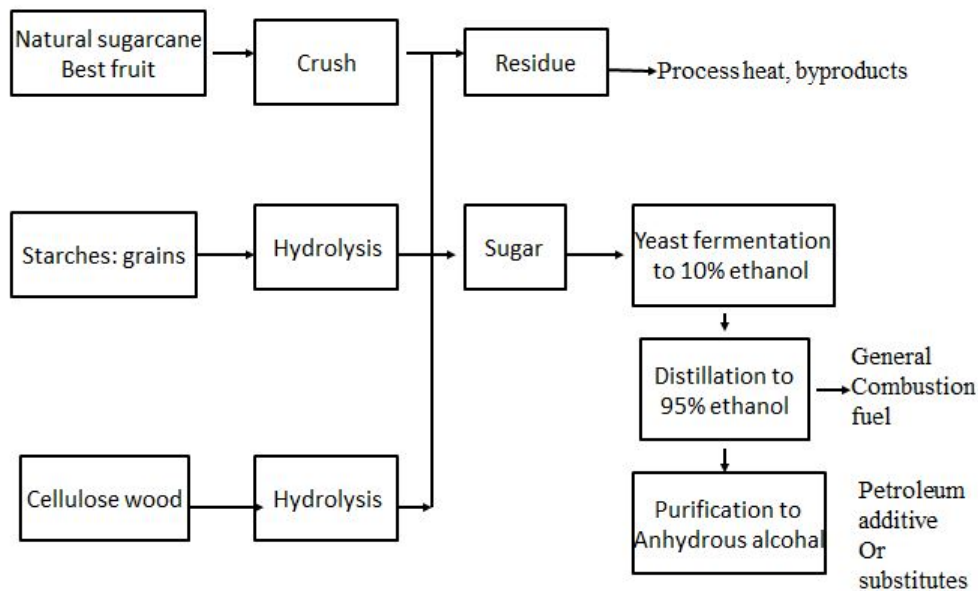

Figure 3.5.3: Ethanol Production Process

- (b) Anaerobic digestion: In the absence of free oxygen, certain micro organisms can obtain their own energy supply by reacting with carbon compounds of medium reduction level to produce CO_2 and fully reduced carbon fuel methane CH_4

3. Physical Conversion Process: Physical Conversion techniques are aimed at physically altering the form of biomass. For example: a) the size reduction of biomass by chipping, pulverizing b) drying to

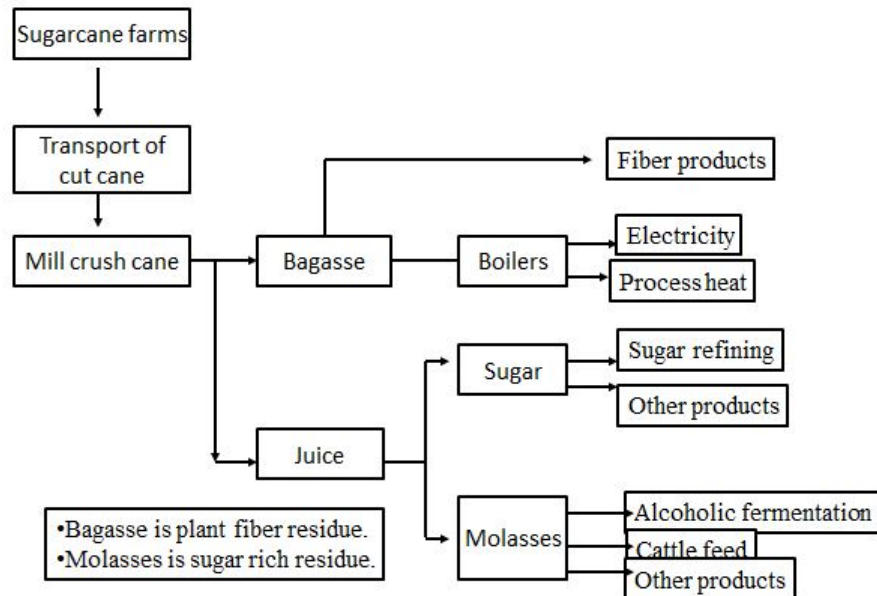

Figure 3.5.4: Biomass example: Sugarcane Agro Industry

reduce water c) Screening d) densification or briquetting. The main purpose is to prepare biomass suitable for combustion .

Biomass briquette is the densification of loose biomass materials (agricultural residues, forestry wastes, animal wastes etc.) to produce compact solid composites of different sizes called briquettes. Densification is the general process of compressing the raw materials to a certain shape or form using a mould and pressure.

Briquette is applied to:

- Improve fuel characteristics
- Combustion efficiency
- Waste utilization
- Easy handling
- Minimize wastage
- Transportation
- Storage

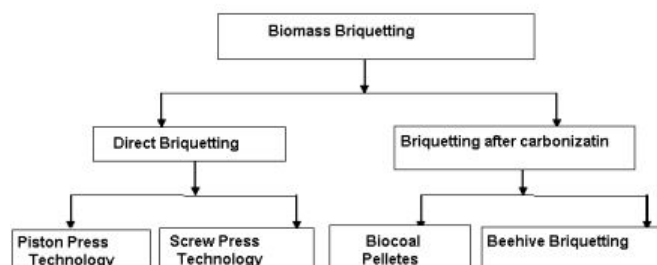

Figure 3.5.5: Briquetting Types

Application of briquette:

- Space heating of residence, lodges and restaurants
- Open Fire Space
- Wool Dyeing Potential Uses

- Tea processing
- Water heating using waste chimney heat
- Cardamom drying
- Vegetable and mushroom drying
- Tobacco curing
- Drying of silk cocoons

4. Agro-chemical Conversion Process

Bioalcohols

Biologically produced alcohols, most commonly ethanol, and less commonly propanol and butanol, are produced by the action of microorganisms and enzymes through the fermentation of sugars or starches, or cellulose. Biobutanol is often claimed to provide a direct replacement for gasoline, because it can be used directly in a gasoline engine

Ethanol fuel is the most common biofuel worldwide, particularly in Brazil. Alcohol fuels are produced by fermentation of sugars derived from wheat, corn, sugar beets, sugar cane, molasses and any sugar or starch from which alcoholic beverages can be made (such as potato and fruit waste, etc.). The ethanol production methods used are enzyme digestion (to release sugars from stored starches), fermentation of the sugars, distillation and drying. The distillation process requires significant energy input for heat (often unsustainable natural gas fossil fuel, but cellulosic biomass such as bagasse, the waste left after sugar cane is pressed to extract its juice, can also be used more sustainably).

Ethanol can be used in petrol engines as a replacement for gasoline; it can be mixed with gasoline to any percentage. Most existing car petrol engines can run on blends of up to 15% bioethanol with petroleum/gasoline. Ethanol has a smaller energy density than that of gasoline; this means it takes more fuel (volume and mass) to produce the same amount of work. An advantage of ethanol CH_3CH_2OH is that it has a higher octane rating than ethanol-free gasoline available at roadside gas stations, which allows an increase of an engine's compression ratio for increased thermal efficiency. In high altitude (thin air) locations, some states mandate a mix of gasoline and ethanol as a winter oxidizer to reduce atmospheric pollution emissions.

Ethanol is also used to fuel bioethanol fireplaces. As they do not require a chimney and are "flueless", bioethanol fires are extremely useful for newly built homes and apartments without a flue. The downside to these fireplaces is their heat output is slightly less than electric heat or gas fires.

Even dry ethanol has roughly one-third lower energy content per unit of volume compared to gasoline, so larger (therefore heavier) fuel tanks are required to travel the same distance, or more fuel stops are required. With large current unsustainable, unscalable subsidies, ethanol fuel still costs much more per distance travelled than current high gasoline prices in the United States.

Methanol is currently produced from natural gas, a non renewable fossil fuel. It can also be produced from biomass as biomethanol. The methanol economy is an alternative to the hydrogen economy, compared to today's hydrogen production from natural gas.

Butanol (C_4H_9OH) is formed by ABE fermentation (acetone, butanol, ethanol) and experimental modifications of the process show potentially high net energy gains with butanol as the only liquid product. Butanol will produce more energy and allegedly can be burned "straight" in existing gasoline engines (without modification to the engine or car), and is less corrosive and less water-soluble than ethanol, and could be distributed via existing infrastructures.

Biodiesel

In some countries, biodiesel is less expensive than conventional diesel. Biodiesel is the most common biofuel in Europe. It is produced from oils or fats using transesterification and is a liquid similar in composition to fossil/mineral diesel. Chemically, it consists mostly of fatty acid methyl (or ethyl) esters. Feedstocks for biodiesel include animal fats, vegetable oils, soy, rapeseed, jatropha, mahua, mustard, flax, sunflower, palm oil, hemp, field pennycress, *Pongamia pinnata* and algae.

Pure biodiesel (B100) is the lowest-emission diesel fuel. Although liquefied petroleum gas and hydrogen have cleaner combustion, they are used to fuel much less efficient petrol engines and are not as widely available. Biodiesel can be used in any diesel engine when mixed with mineral diesel. In some countries, manufacturers cover their diesel engines under warranty for B100 use.

Biodiesel is also safe to handle and transport because it is as biodegradable as sugar, one-tenth as toxic as table salt, and has a high flash point of about 300°F (148°C) compared to petroleum diesel fuel, which has a flash point of 125°F (52°C).

Vegetable Oil

Straight unmodified edible vegetable oil is generally not used as fuel, but lower-quality oil can and has been used for this purpose. Used vegetable oil is increasingly being processed into biodiesel, or (more rarely) cleaned of water and particulates and used as a fuel.

Oils and fats can be hydrogenated to give a diesel substitute. The resulting product is a straight-chain hydrocarbon with a high cetane(?) number, low in aromatics and sulphur and does not contain oxygen. Hydrogenated oils can be blended with diesel in all proportions. They have several advantages over biodiesel, including good performance at low temperatures, no storage stability problems and no susceptibility to microbial attack.

Biogas

A physical structure where methane gas (i.e. biogas) is produced by anaerobic digestion of organic matter. Anaerobic digestion takes place by the action of methanogenic bacteria, which thrive in an environment that lacks air (oxygen) but has favourable temperature. Also known as a bio-digester, bioreactor or anaerobic reactor. Methane have properties like: Burns with higher temperature than kerosene, fuel wood, dung cake, coal etc; an odourless gas ; Burns with a blue flame like LPG; No smoke is produced during its burning; Non poisonous during burning. In principle a biogas plant should have three essential components:

- Digestion Chamber: Chamber where anaerobic condition is ensured and organic matter is digested by methanogenic bacteria and it should be air tight.
- Inlet: to feed organic matter into digestion chamber.
- Outlet: to remove digested matter, i.e., slurry

Biogas may consists of mixtures of Methane (CH_4) 50% to 60%, Carbon dioxide (CO_2) 30% to 40%, Hydrogen (H_2) 5% to 10%, Nitrogen (N_2) 1 % to 2%, Water vapour- About 0.3%, Hydrogen Sulphide (H_2S) in traces.

Benefits:

- Saving of Fuelwood and Kerosene: Biogas replaces the use of fuelwood, Prevents deforestation and saves time
- Health Improvement: Being smokeless biogas reduces respiratory and eye infection in women and children, Toilet connection to Biogas Plants improve sanitation and environment, Reduces water borne diseases -diarrhoea, dysentery, Replacing kerosene by biogas lamps, improves in-house pollution
- Saving of Time: Cooking with biogas saves time for firewood collection, Lesser time for cooking compared to firewood, Possibility of using saved time in income generating activities, recreation, childcare and social activities
- Availability of High Quality Manure: Biogas slurry (Bio-slurry) is an excellent organic fertilizer
- E. Reduction of Womens Workload, Study showed that women can save nearly, 2.8 hours a day due to biogas installation
- Environmental Benefits: Improvement in in-house pollution, management of animal dung and human faeces, Improved sanitation and surroundings
- National and Global Perspective: Nationally Reduction in deforestation; better soil management, conserving soil nutrient, saving expense on fossil fuel, Global Perspective: Reduction in Greenhouse gas emission as one plant reduces 4.6 tones of CO_2 emission per year thus 530,000 tones of CO_2 emission per year by the total installed plants.

3.5.3 Syngas

Syngas, a mixture of carbon monoxide, hydrogen and other hydrocarbons, is produced by partial combustion of biomass, that is, combustion with an amount of oxygen that is not sufficient to convert the biomass completely to carbon dioxide and water. Before partial combustion, the biomass is dried, and sometimes pyrolyzed. The resulting gas mixture, syngas, is more efficient than direct combustion of the original biofuel; more of the energy contained in the fuel is extracted.

Syngas may be burned directly in internal combustion engines, turbines or high-temperature fuel cells. The wood gas generator, a wood-fueled gasification reactor, can be connected to an internal combustion engine.

Syngas can be used to produce methanol, DME and hydrogen, or converted to produce a diesel substitute, or a mixture of alcohols that can be blended into gasoline.

Gasification normally relies on temperatures greater than 700C. Lower temperature gasification is desirable when co-producing biochar, but results in syngas polluted with tar.

Solid Biofuels

Examples include wood, sawdust, grass trimmings, domestic refuse, charcoal, agricultural waste, nonfood energy crops, and dried manure. When raw biomass is already in a suitable form (such as firewood), it can burn directly in a stove or furnace to provide heat or raise steam. When raw biomass is in an inconvenient form (such as sawdust, wood chips, grass, urban waste wood, agricultural residues), the typical process is to densify the biomass. This process includes grinding the raw biomass to an appropriate particulate size (which is then concentrated into a fuel product). The current processes produce wood pellets, cubes, or pucks. The pellet process is most common in Europe, and is typically a pure wood product. The other types of densification are larger in size compared to a pellet, and are compatible with a broad range of input feedstocks. The resulting densified fuel is easier to transport and feed into thermal generation systems, such as boilers.

One of the advantages of solid biomass fuel is that it is often a byproduct, residue or waste-product of other processes, such as farming, animal husbandry and forestry. In theory, this means fuel and food production do not compete for resources, although this is not always the case. A problem with the combustion of raw biomass is that it emits considerable amounts of pollutants, such as particulates and polycyclic aromatic hydrocarbons. Even modern pellet boilers generate much more pollutants than oil or natural gas boilers. Pellets made from agricultural residues are usually worse than wood pellets, producing much larger emissions of dioxins and chlorophenols. Taking this into consideration, the global warming potential (GWP), which is a combination of CO_2 , methane (CH_4), and nitrous oxide (N_2O) emissions, and energy balance of the system need to be examined using a life cycle assessment. This takes into account the upstream processes which remain constant after CO_2 sequestration, as well as the steps required for additional power generation. Firing biomass instead of coal led to a 148 % reduction in GWP. A derivative of solid biofuel is biochar, which is produced by biomass pyrolysis. Biochar made from agricultural waste can substitute for wood charcoal.

Second-generation (advanced) biofuels

Second-generation biofuels are produced from sustainable feedstock. Sustainability of a feedstock is defined, among others, by availability of the feedstock, impact on GHG emissions, and impact on biodiversity and land use. Many second-generation biofuels are under development such as Cellulosic ethanol, Algae fuel., biohydrogen, biomethanol, DMF, BioDME, Fischer-Tropsch diesel (green diesel), biohydrogen diesel, mixed alcohols and wood diesel. Cellulosic ethanol production uses nonfood crops or inedible waste products and does not divert food away from the animal or human food chain. The recent discovery of the fungus *Gliocladium roseum* points toward the production of so-called myco-diesel from cellulose. Scientists working with the New Zealand company Lanzatech have developed a technology to use industrial waste gases, such as carbon monoxide from steel mills, as a feedstock for a microbial fermentation process to produce ethanol. In October 2011, Virgin Atlantic announced it was joining with Lanzatech to commission a demonstration plant in Shanghai that would produce an aviation fuel from waste gases from steel production. Scientists working in Minnesota have developed co-cultures of *Shewanella* and *Synechococcus* that produce long-chain hydrocarbons directly from water, carbon dioxide, and sunlight.

3.6 Hydrogen Energy

The hydrogen atom is composed of one proton and one electron, making it the lightest element in the universe. It is also the most abundant element in the universe, making up more than 90% of all known matter. The abundance of hydrogen on earth, minimal environmental consequences of its use and the need to replace fossil fuels, makes it the ideal fuel of the future. It is colourless, odourless, tasteless and non toxic. Hydrogen exists as a gas at atmospheric temperatures and pressures. A stable molecule because of its high bond strength, hydrogen becomes reactive at elevated temperatures or with the aid of catalysts. When cooled to its boiling point of -423°F -253°C , hydrogen becomes a liquid that is approximately 93 percent lighter than water.

All other gases, except helium, become solids at this temperature. Hydrogen is flammable and burns in air with a pale blue, almost invisible flame.

In its gaseous form, hydrogen dissipates quickly. These unique properties call for strict safety measures in hydrogen use and storage.

Hydrogen has been identified as a potential energy carrier in many low GHG energy scenarios. However, the technology to produce, distribute and use hydrogen in a cost effective, low GHG manner is not yet developed.

Hydrogen has the potential to run a fuel-cell engine with greater efficiency over an internal combustion engine. The same amount of hydrogen will take a fuel-cell car at least twice as far as a car running on gasoline.

Hydrogen can be produced from fossil fuels or from water splitting. When hydrogen is derived from hydrocarbons (fossil fuels), the chemical energy to be stored in the hydrogen is already present in the primary fuel. The key challenges to this form of production lie in controlling the chemical reactions and the extraction of hydrogen. Production from fossil fuels in a low GHG scenario will also require CO_2 capture and sequestration. Conversely, extraction of hydrogen from water requires that energy be supplied from an external resource, but does not present the challenge of unwanted emissions at the point of conversion.

Hydrogen's appeal as an energy carrier is limited by its ability to be efficiently stored. Many energy conversion systems that would use hydrogen must operate intermittently and thereby require a reservoir of hydrogen. This reservoir must be of reasonable size and weight, and cannot waste a significant fraction of stored energy in the filling and venting processes.

The two most likely candidates for the conversion of energy stored in hydrogen to useful work are internal combustion engines and fuel cells. Today's engine technology could be adapted for use with hydrogen at efficiencies comparable to hydrocarbon fueled engines, while advanced engine technology could push the boundaries of efficiency even further. Fuel cells hold the promise of higher efficiency than traditional engines, as well as other engineering trade-off that might make for quieter and possibly more reliable prime movers. Replacing fossil-fuel based vehicles and electric power plants with those powered by hydrogen fuel cells may affect global and regional climate, stratospheric ozone, and air pollution.

Production

There are several methods for producing or extracting hydrogen. Steam reforming is a well-established technology that allows hydrogen production from hydrocarbons and water. Steam-methane reformation currently produces about 95 percent of the hydrogen used in the United States.

Another conventional technique is electrolysis, which applies electrical current to decompose water into hydrogen and oxygen molecules. The electricity for electrolysis can come from any of the three energy sources.

The cost of hydrogen production is an important issue. Hydrogen produced by steam reformation costs approximately three times the cost of natural gas per unit of energy produced. This means that if natural gas costs \$6/million BTU, then hydrogen will be \$18/million BTU. Also, producing hydrogen from electrolysis with electricity at 5 cents/kWh will cost \$28/million BTU slightly less than two times the cost of hydrogen from natural gas. Note that the cost of hydrogen production from electricity is a linear function of electricity costs, so electricity at 10 cents/kWh means that hydrogen will cost \$56/million BTU.

Storage

In the case of on-board storage of hydrogen for vehicular applications, automobile manufacturers require lightweight, compact, safe, and cost-effective storage plus the ability to achieve a driving range of at

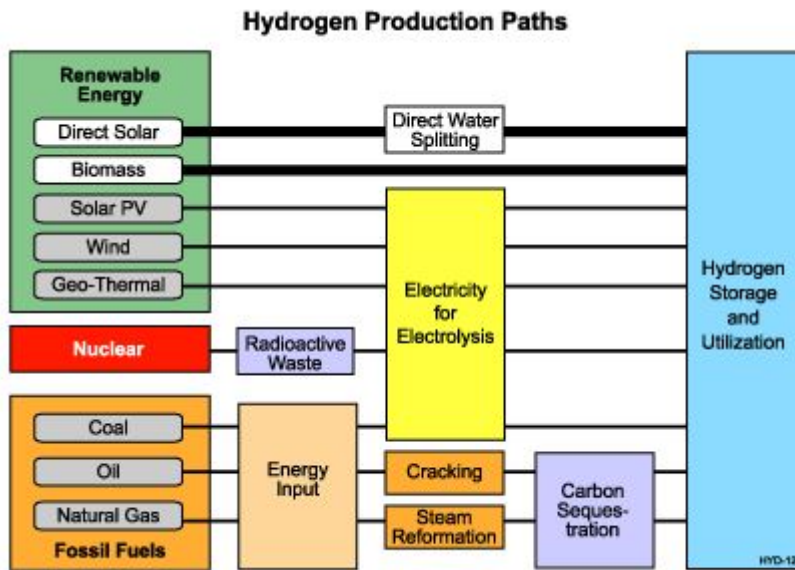

Figure 3.6.1: Hydrogen Production

least 300 miles. The 300-mile driving range requires 5-10 kg of usable hydrogen depending upon the size of the vehicle. Although various hydrogen storage technologies are presently available, none completely satisfies all of the auto industry requirements. In fact, finding a solution to the hydrogen storage problem is considered by many to be the foremost challenge for the hydrogen economy.

Hydrogen can be stored in three ways:

- As a compressed gas in high-pressure tanks.
- As a liquid in dewars or tanks (stored at -253°C).
- As a solid by either absorbing or reacting with metals or chemical compounds or storing in an alternative chemical form.

Storage of hydrogen in chemical compounds offers a much wider range of possibilities to meet the transportation requirements, but no single material investigated to date exhibits all the necessary properties. At present, only three systems for on-board hydrogen storage are close to commercialization. They are compressed gas at high pressures (5,000 to 10,000 psi in composite cylinders), liquid hydrogen which requires a cryogenic temperature of -253°C , and materials-based storage in solids which involves the use of metal hydrides, carbon-based materials/high surface area sorbents, and/or chemical hydrogen storage.

The current status of various storage technologies in terms of weight, volume and costs is given in Table 3.6.1.

Storage Technologies	Weight(kwh/kg)	Volume (kwh/L)	Cost (\$/kwh)
Chemical Hydrides	1.6	1.4	8
Complex Metal Hydrides	0.8	0.6	16
Liquid Hydrogen	2.0	1.6	6
10,000-psi Gas	1.9	1.3	16
DOE Goals (2015)	3.0	2.7	2

Table 3.6.1: Status of various storage technologies.

Delivery

Safety and handling are the two main issues with hydrogen delivery and use. Because hydrogen is such a light gas, it escapes readily, making its transportation and handling more difficult than natural gas. Hydrogen also has a wider flammability range than natural gas in air, making it potentially more

hazardous. And when hydrogen burns there is no colour - the flame is invisible. Improved sensing devices will need to be developed and building codes adjusted to address these challenges.

Safety

The detection of explosive conditions in hydrogen applications is important for both safety and economic reasons. Cost-effective hydrogen sensor technologies that deliver detection selectivity and sensitivity, dependability and durability, stability and reproducibility, resistance to chemical degradation and real-time response are needed. An examination of the commercially available point-contact hydrogen sensors indicates the majority of these sensors fall into four main categories: catalytic combustion, electrochemical, semi-conducting oxide sensors and thermal conductivity detectors. All of these sensors depend on the interaction of hydrogen with palladium (Pd) or Pd-based alloys.

Vehicle applications require the development of new sensors with capabilities beyond those of commercially available systems. Areas of most interest include micro-machining and micro-fabrication technology to fabricate miniaturized sensors. In addition, new techniques that allow control and interrogation of each sensor and provide self-calibrating capability are needed.

3.6.1 Advantages and Disadvantages

Advantages:

- When hydrogen is burned, the only emission it makes is water vapor, so a key advantage of hydrogen is that when burned, carbon dioxide CO_2 is not produced.
- Clearly, hydrogen is less of a pollutant in the air because it omits little tail pipe pollution.
- Hydrogen has the potential to run a fuel-cell engine with greater efficiency over an internal combustion engine.
- The same amount of hydrogen will take a fuel-cell car at least twice as far as a car running on gasoline.

Disadvantages:

1. Currently, it still costs a considerable amount of money to run a hydrogen vehicle because it takes a large amount of energy to liquefy the fuel.
2. Research shows that cars could store hydrogen in high pressure tanks like those used for compressed natural gas. It would need to be packed tightly into a car's tank in order to avoid countless trips to the filling station every few miles.

3.6.2 Applications

- Hydrogen is used extensively today to make ammonia, methanol, gasoline, heating oil, and rocket fuel. It is also used to make fertilizers, glass, refined metals, vitamins, cosmetics, semiconductor circuits, soaps, lubricants, cleaners, and even margarine and peanut butter. Hydrogen can fuel today's internal combustion engine vehicles.
- Hydrogen can fuel tomorrow's fuel-cell vehicles.
- Hydrogen can replace today's natural gas for heating and cooling homes and powering hot water heaters.
- Existing wind and hydroelectric plants can produce hydrogen to store energy during off-peak hours.
- Hydrogen production from hydrocarbons can also produce carbon, which in some forms has ten times the strength of steel. With more research, this carbon could be used for automobile bodies and structural members

3.7 Fuel Cells

(Taken from <http://americanhistory.si.edu/fuelcells/basics.htm>) A fuel cell is a device that generates electricity by a chemical reaction. Every fuel cell has two electrodes, one positive and one negative, called, respectively, the anode and cathode. The reactions that produce electricity take place at the electrodes.

Every fuel cell also has an electrolyte, which carries electrically charged particles from one electrode to the other, and a catalyst, which speeds the reactions at the electrodes.

Hydrogen is the basic fuel, but fuel cells also require oxygen. One great appeal of fuel cells is that they generate electricity with very little pollution much of the hydrogen and oxygen used in generating electricity ultimately combine to form a harmless byproduct, namely water.

One detail of terminology: a single fuel cell generates a tiny amount of direct current (DC) electricity. In practice, many fuel cells are usually assembled into a stack. Cell or stack, the principles are the same.

3.7.1 Principle of Operation

The purpose of a fuel cell is to produce an electrical current that can be directed outside the cell to do work, such as powering an electric motor or illuminating a light bulb or a city. Because of the way electricity behaves, this current returns to the fuel cell, completing an electrical circuit. The chemical reactions that produce this current are the key to how a fuel cell works.

There are several kinds of fuel cells, and each operates a bit differently. But in general terms, hydrogen atoms enter a fuel cell at the anode where a chemical reaction strips them of their electrons. The hydrogen atoms are now "ionized," and carry a positive electrical charge. The negatively charged electrons provide the current through wires to do work. If alternating current (AC) is needed, the DC output of the fuel cell must be routed through a conversion device called an inverter.

Oxygen enters the fuel cell at the cathode and, in some cell types (like the one illustrated above), it there combines with electrons returning from the electrical circuit and hydrogen ions that have traveled through the electrolyte from the anode. In other cell types the oxygen picks up electrons and then travels through the electrolyte to the anode, where it combines with hydrogen ions.

The electrolyte plays a key role. It must permit only the appropriate ions to pass between the anode and cathode. If free electrons or other substances could travel through the electrolyte, they would disrupt the chemical reaction.

Whether they combine at anode or cathode, together hydrogen and oxygen form water, which drains from the cell. As long as a fuel cell is supplied with hydrogen and oxygen, it will generate electricity.

Even better, since fuel cells create electricity chemically, rather than by combustion, they are not subject to the thermodynamic laws that limit a conventional power plant (see "Carnot Limit" in the glossary). Therefore, fuel cells are more efficient in extracting energy from a fuel. Waste heat from some cells can also be harnessed, boosting system efficiency still further.

The type of fuel also depends on the electrolyte. Some cells need pure hydrogen, and therefore demand extra equipment such as a "reformer" to purify the fuel. Other cells can tolerate some impurities, but might need higher temperatures to run efficiently. Liquid electrolytes circulate in some cells, which requires pumps. The type of electrolyte also dictates a cell's operating temperature"molten" carbonate cells run hot, just as the name implies.

Fuel cell technology is twice as efficient as combustion in turning carbon fuel to energy. Hydrogen, the simplest chemical element (one proton and one electron), is plentiful and exceptionally clean as a fuel. Hydrogen makes up 90 percent of the universe and is the third most abundant element on the earth's surface. Such a wealth of fuel would provide an almost unlimited pool of clean energy at relatively low cost. But there is a hitch.

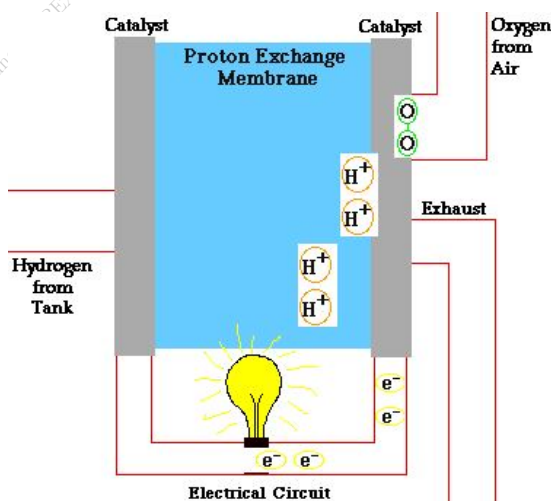

Figure 3.7.1: Fuel cell operations.

Each type of fuel cell has advantages and drawbacks compared to the others, and none is yet cheap and efficient enough to widely replace traditional ways of generating power, such coal-fired, hydroelectric, or even nuclear power plants.

The following section describes the five main types of fuel cells.

3.7.2 Types of Fuel Cells

Alkali

Alkali fuel cells operate on compressed hydrogen and oxygen. They generally use a solution of potassium hydroxide (chemically, KOH) in water as their electrolyte. Efficiency is about 70 percent, and operating temperature is 150 to 200 degrees C, (about 300 to 400 degrees F). Cell output ranges from 300 watts (W) to 5 kilowatts (kW). Alkali cells were used in Apollo spacecraft to provide both electricity and drinking water. They require pure hydrogen fuel, however, and their platinum electrode catalysts are expensive. And like any container filled with liquid, they can leak.

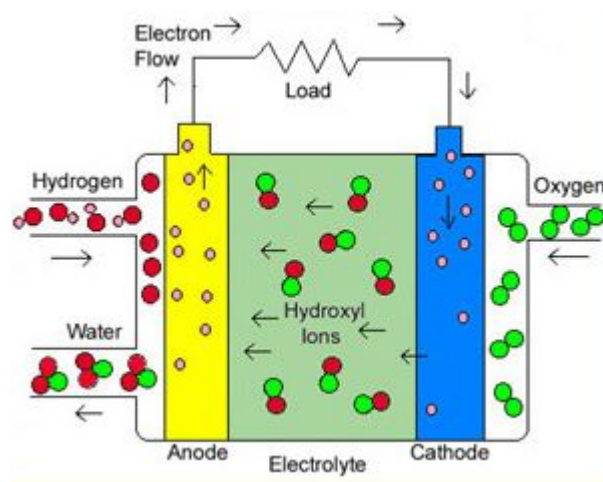

Figure 3.7.2: Alkali Fuel Cell

Molten Carbonate

Molten Carbonate fuel cells (MCFC) use high-temperature compounds of salt (like sodium or magnesium) carbonates (chemically, CO_3) as the electrolyte. Efficiency ranges from 60 to 80 percent, and operating temperature is about 650 degrees C (1,200 degrees F). Units with output up to 2 megawatts (MW) have been constructed, and designs exist for units up to 100 MW. The high temperature limits damage from carbon monoxide "poisoning" of the cell and waste heat can be recycled to make additional electricity. Their nickel electrode-catalysts are inexpensive compared to the platinum used in other cells. But the high temperature also limits the materials and safe uses of MCFC—they would probably be too hot for home use. Also, carbonate ions from the electrolyte are used up in the reactions, making it necessary to inject carbon dioxide to compensate.

Phosphoric Acid

Phosphoric Acid fuel cells (PAFC) use phosphoric acid as the electrolyte. Efficiency ranges from 40 to 80 percent, and operating temperature is between 150 to 200 degrees C (about 300 to 400 degrees F). Existing phosphoric acid cells have outputs up to 200 kW, and 11 MW units have been tested. PAFCs tolerate a carbon monoxide concentration of about 1.5 percent, which broadens the choice of fuels they can use. If gasoline is used, the sulfur must be removed. Platinum electrode-catalysts are needed, and internal parts must be able to withstand the corrosive acid.

Proton Exchange Membrane (PEM)

Proton Exchange Membrane (PEM) fuel cells work with a polymer electrolyte in the form of a thin, permeable sheet. Efficiency is about 40 to 50 percent, and operating temperature is about 80 degrees C

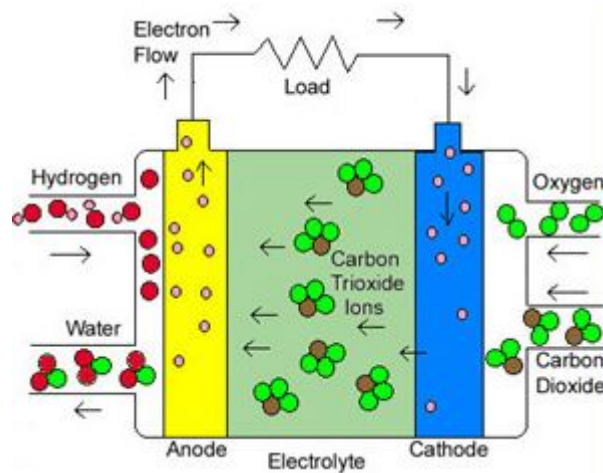

Figure 3.7.3: Molten Carbonate

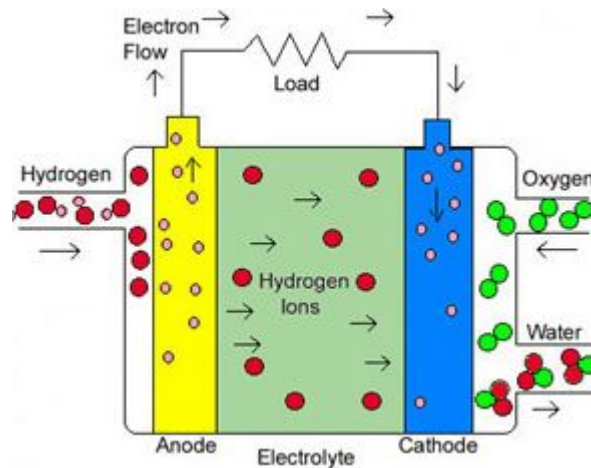

Figure 3.7.4: Phosphoric Acid

(about 175°F). Cell outputs generally range from 50 to 250 kW. The solid, flexible electrolyte will not leak or crack, and these cells operate at a low enough temperature to make them suitable for homes and cars. But their fuels must be purified, and a platinum catalyst is used on both sides of the membrane, raising costs.

Solid Oxide

Solid Oxide fuel cells (SOFC) use a hard, ceramic compound of metal (like calcium or zirconium) oxides (chemically, O_2) as electrolyte. Efficiency is about 60 percent, and operating temperatures are about 1,000 degrees C (about 1,800 degrees F). Cells output is up to 100 kW. At such high temperatures a reformer is not required to extract hydrogen from the fuel, and waste heat can be recycled to make additional electricity. However, the high temperature limits applications of SOFC units and they tend to be rather large. While solid electrolytes cannot leak, they can crack.

Two possible design configurations for SOFCs have emerged: a planar design and a tubular design. In the planar design, the components are assembled in flat stacks, with air and fuel flowing through channels built into the cathode and anode. In the tubular design, components are assembled in the form of a hollow tube, with the cell constructed in layers around a tubular cathode; air flows through the inside of the tube and fuel flows around the exterior.

3.7.3 Material selection for Fuel Cells

Although the operating concept of FC is rather simple, the selection of materials for the individual components presents enormous challenges. Each material must have the electrical properties required

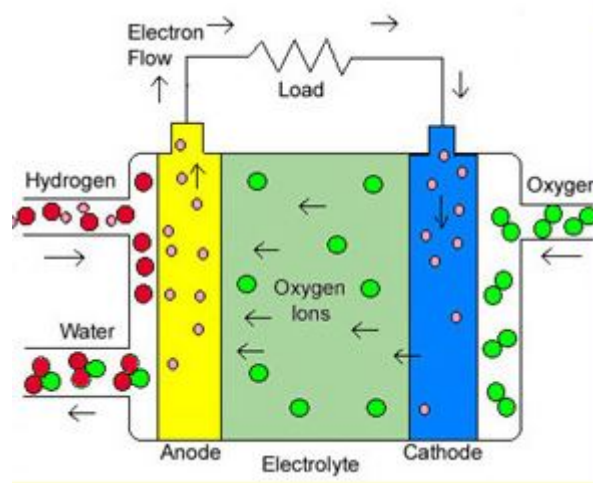

Figure 3.7.5: Solid Oxide

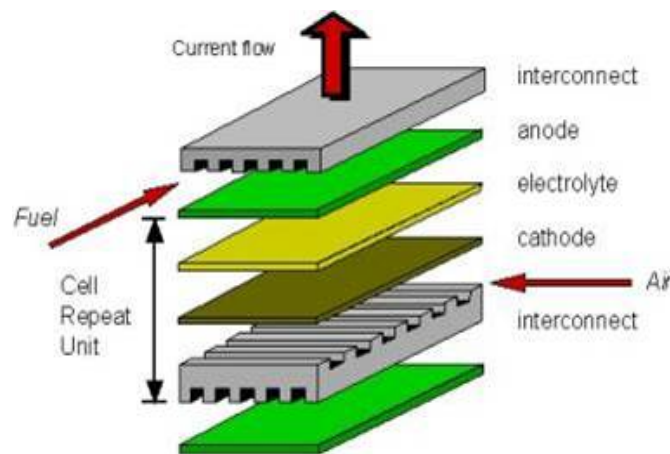

Figure 3.7.6: Planar Solid Oxide

to perform its function in the cell. There must be enough chemical and structural stability to endure fabrication and operation at high temperatures. The fuel cell needs to run at high temperatures in order to achieve sufficiently high current densities and power output. Reactivity and inter-diffusion between the components must be as low as possible. The thermal expansion coefficients of the components must be as close to one another as possible in order to minimize thermal stresses which could lead to cracking and mechanical failure. The air side of the cell must operate in an oxidizing atmosphere and the fuel side must operate in a reducing atmosphere. The temperature and atmosphere requirements drive the materials selection for all the other components.

Cathode

The cathode must meet all the above requirements and be porous in order to allow oxygen molecules to reach the electrode/electrolyte interface. In some designs (e.g. tubular) the cathode contributes over 90% of the cell's weight and therefore provides structural support for the cell

Anode

The anode (the fuel electrode) must meet most of the same requirements as the cathode for electrical conductivity, thermal expansion compatibility and porosity, and must function in a reducing atmosphere. The reducing conditions combined with electrical conductivity requirements make metals attractive candidate materials.

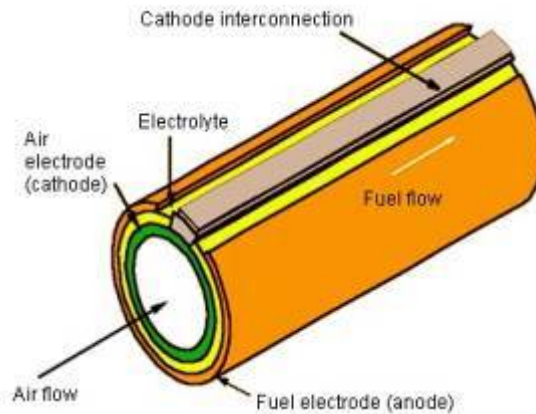

Figure 3.7.7: Tubular Solid Oxide

Electrolyte

Once the molecular oxygen has been converted to oxygen ions it must migrate through the electrolyte to the fuel side of the cell. In order for such migration to occur, the electrolyte must possess a high ionic conductivity and no electrical conductivity. It must be fully dense to prevent short circuiting of reacting gases through it and it should also be as thin as possible to minimize resistive losses in the cell. As with the other materials, it must be chemically, thermally, and structurally stable across a wide temperature range.

Interconnect

Just as an internal combustion engine relies on several cylinders to provide enough power to be useful, so too must fuel cells be used in combination in order to generate enough voltage and current. This means that the cells need to be connected together and a mechanism for collection of electrical current needs to be provided, hence the need for interconnects. The interconnect functions as the electrical contact to the cathode while protecting it from the reducing atmosphere of the anode.

The high operating temperature of the cells combined with the severe environments means that interconnects must meet the most stringent requirements of all the cell components: 100% electrical conductivity, no porosity (to avoid mixing of fuel and oxygen), thermal expansion compatibility, and inertness with respect to the other fuel cell components. It will be exposed simultaneously to the reducing environment of the anode and the oxidizing atmosphere of the cathode.

Chapter 4

Environmental Impact of Energy Sources

4.1 Emission Hazard

4.1.1 Indoor Pollutants

Household combustion of coal or biomass (e.g.; dung, charcoal, wood, crop residues) can cause emission hazards. These fuels are used for household cooking and heating. Solid fuels are burned in inefficient simple stoves and in poorly ventilated conditions. The disease burden from solid fuel use is most significant in populations with inadequate access to clean fuels, particularly poor households in rural areas of developing countries. Women and their youngest children are most exposed because of their household roles.

In simple stoves, biomass fuels emit substantial amounts of health-damaging pollutants, including respirable particulates, carbon monoxide, nitrogen oxides, benzene, formaldehyde, 1,3 butadiene, and polyaromatic compounds such as benzo(α)pyrene. Depending on their quality, coal fuels may also emit sulphur oxides and other toxic elements, including arsenic, lead and fluorine. Coals smoke produces all the above plus, depending on coal quality, sulphur oxides and such toxic elements as arsenic, lead, fluorine, and mercury.

Environmental Impact of Indoor Pollutant

1. Acid precipitation
2. Destruction of global nitrogen cycle
3. Ground level ozone
4. Deforestation
5. Diversion of agricultural residues
6. Loss of visibility, property or crops

Effect of Indoor Pollution on Health

1. **Strong evidence:** ARIs (acute respiratory infections), Chronic obstructive lung disease, Lung cancer
2. **Moderate evidence:** Cataract, TB (tuberculosis)
3. **Limited evidence:** Asthma
4. **Insufficient evidence:** Low birth weight and perinatal deaths, Heart disease etc

Efforts to Reduce Indoor Air Pollutants

Three factors determine the extent to which Indoor Air Pollutants(IAP) impacts health:

- the degree of pollution, that is, the emission levels;
- the degree of exposure, that is, the amount of time spent in a polluted environment;
- personal susceptibility to the effects of IAP, that is, physiological factors that make some individuals more prone to the effects than others, such as children and asthmatics.

Technical interventions can thus reduce IAP in three ways (Ballard-Tremeer and Mathee, 2000):

- **by producing less smoke:** improved stoves, improved fuels and fuel switching;
- **by removing smoke from the indoor environment:** chimneys, flues, hoods and ventilation;
- **by reducing exposure to smoke:** reducing cooking time, behaviour, kitchen design.

Others controlling measures can be housing design, behavioural changes like education, reducing smoke from stove, modified cooking practice.

4.1.2 Automotive Pollution

Exhaust gas or flue gas is emitted as a result of the combustion of fuels such as natural gas, gasoline/petrol, diesel fuel, fuel oil or coal. According to the type of engine, it is discharged into the atmosphere through an exhaust pipe. Motor vehicle emissions contribute to air pollution and are a major ingredient in the creation of smog in some large cities.

The largest part of most combustion gas is nitrogen (N_2), water vapor (H_2O) (except with pure-carbon fuels), and carbon dioxide (CO_2) (except for fuels without carbon); these are not toxic or noxious (although carbon dioxide is a greenhouse gas that contributes to global warming). A relatively small part of combustion gas is undesirable noxious or toxic substances, such as carbon monoxide (CO) from incomplete combustion, hydrocarbons (properly indicated as C_xH_y , but typically shown simply as "HC" on emissions-test slips) from unburnt fuel, nitrogen oxides (NO_x) from excessive combustion temperatures, ozone (O_3), and particulate matter (mostly soot).

Health Impacts

Carbon monoxide (CO) affects especially persons with heart disease, and fetuses. Unburned hydrocarbon (HC) has serious health effect on people who suffer from lung diseases, asthma or emphysema. Nitrogen oxides (NO_x) is linked to a wide range of respiratory problems; cough, runny nose, and sore throat are among the most common. Ozone can cause chest pain, coughing, and shortness of breath. When inhaled, ozone can cause temporary decreases in lung function of 15 to over 20% in healthy adults. Lead exposure will lead to a decrease in intelligence quotient and can, in some cases, also lead to premature deaths. Particulate matter (PM) is associated with premature death, aggravation of respiratory and cardiovascular disease, and decrease in lung function.

4.2 Battery Hazards

Batteries are safe, but precaution applies when touching damaged cells and when handling lead acid systems that have access to lead and sulphuric acid. Several countries label lead acid as hazardous material, and rightly so. Let's look at the hazards if not properly handled.

4.2.1 Explosion

A battery explosion is caused by misuse or malfunction, such as attempting to recharge a primary (non-rechargeable) battery, or a short circuit. Car batteries are most likely to explode when a short-circuit generates very large currents. Car batteries produce hydrogen, which is very explosive, when they are overcharged (because of electrolysis of the water in the electrolyte). When a battery is recharged at an excessive rate, an explosive gas mixture of hydrogen and oxygen may be produced faster than it can escape from within the battery, leading to pressure build-up and eventual bursting of the battery case. It may also cause damage to the charger or device.

4.2.2 Explosion

The sulphuric acid in a lead acid battery is highly corrosive and is potentially more harmful than acids used in other battery systems. Eye contact can cause permanent blindness; swallowing damages internal organs that can lead to death. First aid treatment calls for flushing the skin for 10 to 15 minutes with large amounts of water to cool the affected tissues and to prevent secondary damage. Immediately remove contaminated clothing and thoroughly wash the underlying skin. Always wear protective equipment when handling the sulphuric acid.

4.2.3 Poisoning

Lead poisoning can lead to brain disease, slowed nerve conduction velocity [decreased reaction times], slow growth and development of child, effect in cognitive development like levels decrease in IQ, cognitive function deficits such as verbal function / linguistic deficits. Other effects include learning difficulties, hearing impairment; lack in auditory sensitivity, sight loss and impairment etc and problems in digestive system.

Effects of cadmium include accumulation on kidney (where it damages filtering mechanisms, dysfunction), lung impairment, bone disease, human carcinogenesis, diarrhoea, stomach pains and severe vomiting reproductive failure and possibly even infertility, damage to the central nervous system, damage to the immune system.

Nickel-metal-hydride is considered non-toxic and the only concern is the electrolyte. Although toxic to plants, nickel is not harmful to humans. Lithium-ion is similarly benign the battery contains little toxic material. Nevertheless, caution is required when working with a damaged battery. When handling a spilled battery, do not touch your mouth, nose and eyes, and wash your hands thoroughly.

4.2.4 Toxic Materials

Many types of batteries employ toxic materials such as lead, mercury, and cadmium as an electrode or electrolyte. When each battery reaches end of life it must be disposed of to prevent environmental damage. Batteries are one form of electronic waste (e-waste).

4.2.5 Safety Methods

1. Keep button batteries out of sight and reach of children. Remote controls, singing greeting cards, watches, hearing aids, thermometers, toys, electric keys and more may include these batteries.
2. Keep loose batteries locked away to prevent access by small children.
3. Share the danger of swallowing button batteries with caregivers, friends, family members and baby sitters.
4. If you suspect your child has ingested a battery, go to the hospital immediately. Wait for a medical assessment before allowing the child to eat and drink.
5. As a simple guideline, hydrogen sulphide which comes after over charging batteries, becomes harmful to human life if the odour is noticeable. Turn off the charger, vent the house and stay outside until the odour disappears.

4.2.6 Recycling of Batteries

Lead acid batteries are usually composed of two plates: Pb alloy and PbO_2 base. During the batteries discharge, $PbSO_4$ is formed. The PbO_2 base plate is essentially composed of a Pb alloy grate in which a PbO_2 paste is impregnated. The grates are normally composed of alloys containing low amounts of Ca, Sb and Sn. The electrolyte used is a sulphuric acid solution. A polypropylene box typically contains the electrolyte and a group of six cells.

The recycling sequential steps normally are:

1. the separation of the plastic case
2. acid removal
3. separation of the plastic, metallic lead and paste
4. separation, reduction, refining and casting

4.3 Nuclear Hazard

A number of nuclear explosions have already been made during recent past in different part of world. Irrespective of judgements about the ethics of this practice, these tests occurred, injecting substantial amounts of radioactivity into the environment. Nuclear explosions are very rapid and based on a rough estimate, in an explosion about 50 per cent of the energy goes to the blast, 33 per cent as heat and the rest 17 per cent or so to radioactivity.

The radioactive dust that falls to the earth after atomic explosion is called radioactive fallout. The estimated percept dose to world population from fallout of past nuclear explosions is 10 *microsievert per year*.

4.3.1 Biological Effect of Radioactive Radiation

Radioactive substances are among the most toxic substances known. Radium is 25,000 times more lethal than arsenic. The cell, which is the fundamental unit of life, is the primary site of radiation damage. If too many cells are damaged, the symptoms show up in the growing tissues as in the case of loss of hair, ulceration of the mouth, the reddening and haemorrhaging of the skin and lowering of the blood count. If these symptoms grow more severe, death will result.

Somatic Effects

These are the direct results of action of radiation on the body cell and tissues. These effects may be immediate or delayed. The illness to become a victim are-cardiovascular disorder, cataract, leukaemia, sterility, premature ageing and shortenings of life span. All these are somatic effects.

Genetic Effects

There is another more serious type of effect of ionizing radiations, known as genetic effect. This arises from the damage to the sex cells. If a sex cell is damaged and if that sex cell is one of the pair that goes into the production of a fertilized ovum, it will give rise to an offspring with various kinds of major or minor physical defects.

Radioactive Waste

There is no way of destroying radioactivity. The radioactive waste from nuclear plants may be in form of gases, liquids or solids. There is no suitable and cheap method of storing the radioactive waste. At any time, radioactivity is likely to escape from the waste in water bodies, concrete cases and salt formations in high mountains. The nuclear waste is thus likely to get leached into the biosphere. Among the long-lived fission products the most hazardous are Strontium-90 (half life 28.9y) and caesium- 137 (half life 30.2y).

The highly toxic alpha-active element plutonium (half life 24,100y) is another reactor product that has to be taken care of. All these elements enter the human system and get deposited in various parts of the body causing cell damage. Radionuclides have become distributed throughout the environment and are transmitted to man via the food chain. When taken in by man, some radio nuclides become concentrated in specific organs where they become injurious to health.

Chapter 5

Energy Storage

The way energy is stored depends primarily on the source of energy. According to the latter, we know the following methods of energy storage:

1. **Chemical energy storage:** Chemical energy is a form of potential energy, storage of which further depends on its source. We know the following methods or mediums for chemical energy storage:
 - (a) **Hydrogen.** Although the colourless, odourless, tasteless and non-toxic gas has potentials as a source of energy, it is primarily used as an energy storage medium for subsequent use. Examples include underground hydrogen storage involving the use of underground caverns and empty gas and oil fields to store grid energy for intermittent energy resources such as wind power and solar energy for instance.
 - (b) **Biofuels and biomass.** They do not refer to energy storage as such but are rather examples of chemical energy storage. When wood logs or biofuels are burned, they release energy that is stored in the bonds of molecules and atoms.
 - (c) **Liquid nitrogen.** Just like hydrogen, liquid nitrogen shows potentials as a source of energy but instead, it is used as a form of energy storage. It can be used to generate electricity or refrigeration and cooling.
 - (d) **Oxy-hydrogen.** It is a mixture of oxygen and hydrogen which when ignited, releases high pressure and high temperature steam that can be used to generate electricity.
 - (e) **Other.** There are many other mediums to store chemical energy. Examples include: **hydrogen peroxide**; it is best known for its uses as bleach and cleaning agent although it is also used as rocket fuel and **vanadium pentoxide**; it is used in vanadium redox batteries, a type of flow batteries that are used to store various forms of chemical energy including electric power produced by wind farms
2. **Electrochemical energy storage.** It involves the use of various devices which convert chemical energy into electricity. Examples include: **Battery.** It is a widely used device that converts stored chemical energy into electricity. Two basic types of batteries exist which known as the primary batteries or non-rechargeable batteries and secondary batteries which can be recharged and used multiple times.

Fuel cell. It refers to a device which converts chemical energy into electricity through chemical reaction. Several different types of fuel cells exist but all feature a cathode, anode and an electrolyte.
3. **Electrical energy storage.** It involves the use of an electric field to store energy. Examples include: **Capacitor and supercapacitor (double-layer capacitor).** Both are electrical components that are used to store electric charge but as its name reveals, supercapacitor can store more electric charge. Capacitor is typically used a short-term backup power, while supercapacitor can also be used to power large engines including vehicles. But it is also often used to run low-power devices such as portable media players, PC Cards, etc..

Superconducting magnetic energy storage (SMES). It refers to a relatively new technology which stores electricity from the grid within a magnetic field that is created by the flow of current in a coil.

4. **Thermal energy storage.** It refers to methods that are used to store thermal energy in order to use it to cool or heat buildings when the temperature inside is above or below the internal energy in the stored substance.
 - (a) Hot water storage tank. It refers to a water tank that stores hot water for space heating, washing, bathing, etc.. Hot water storage tanks are a common feature of wood furnaces and solar thermal collectors.
 - (b) Storage heater. It is an electric heater that stores energy during the evening or night and releases heat during the day when the price of base load electricity is higher. Storage heaters work by accumulating heat in ceramic material or clay bricks.
 - (c) Steam accumulator. It refers to a steel tank that contains steam under pressure. It is used to balance between supply and demand by accepting steam when the supply is greater than demand and to release it when demand exceeds the supply.
5. Mechanical energy storage. Methods to store energy that is produced by motion include:
 - (a) Hydraulic accumulator. It is a storage reservoir which stores non-compressible fluid under pressure. There are several types of hydraulic accumulators but the most widely used is the so-called compressed gas accumulator which contains gas under pressure, usually nitrogen.
 - (b) Flywheel energy storage. Like its name suggests, it is a method to store energy through a flywheel. This type of mechanical energy storage is used to store grid energy and energy that is generated by wind farms but it also shows potentials in transportation and as an emergency power source.

5.1 Hybrid Vehicles

A hybrid vehicle is a vehicle that uses two or more distinct power sources to move the vehicle. The term most commonly refers to hybrid electric vehicles (HEVs), which combine an internal combustion engine and one or more electric motors. However, other mechanisms to capture and use energy may also be included.

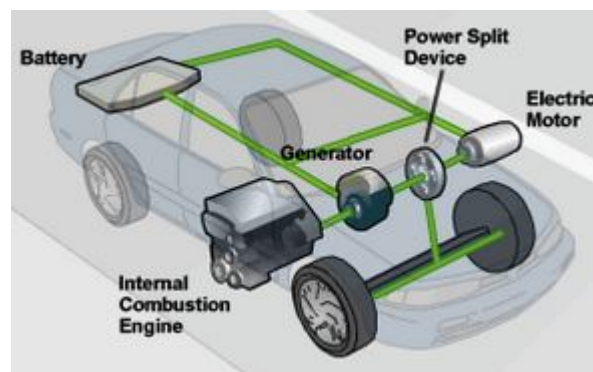

Figure 5.1.1: Hybrid vehicle having two source, petroleum and electricity.

Different power sources like coal, wood, LPG, hydrogen, petrol, solar, wind, human powered can be used.

Hybrid-electric vehicles (HEVs) combine the benefits of gasoline engines and electric motors and can be configured to obtain different objectives, such as improved fuel economy, increased power, or additional auxiliary power for electronic devices and power tools.

Some of the advanced technologies typically used by hybrids include

1. **Regenerative Braking.** The electric motor applies resistance to the drivetrain causing the wheels to slow down. In return, the energy from the wheels turns the motor, which functions as a generator, converting energy normally wasted during coasting and braking into electricity, which is stored in a battery until needed by the electric motor.

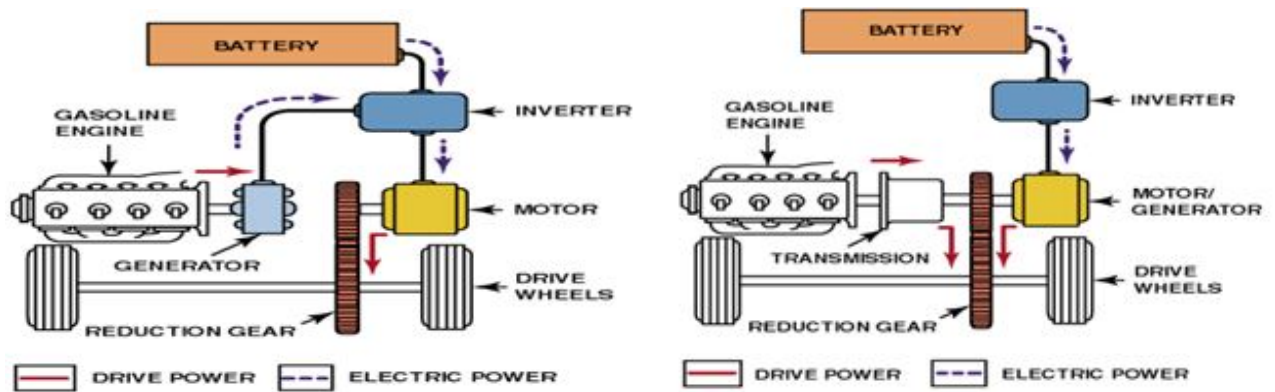

(a) Series hybrid vehicles.

(b) Parallel hybrid vehicles.

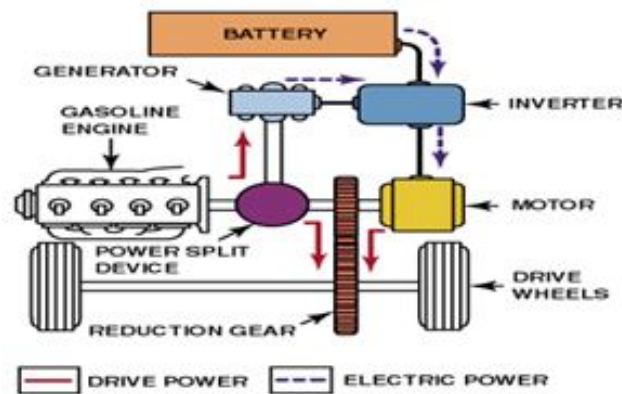

(c) Series parallel hybrid vehicles.

Figure 5.1.2: Hybrid vehicles types..

- 2. Electric Motor Drive/Assist.** The electric motor provides additional power to assist the engine in accelerating, passing, or hill climbing. This allows a smaller, more efficient engine to be used. In some vehicles, the motor alone provides power for low-speed driving conditions where internal combustion engines are least efficient.
- 3. Automatic Start/Shutdown.** Automatically shuts off the engine when the vehicle comes to a stop and restarts it when the accelerator is pressed. This prevents wasted energy from idling.

5.1.1 Types

Series Hybrid

Vehicle propulsion is by a electric motor only, Internal Combustion Engine(ICE) is used for charging the HV battery.

Parallel Hybrid

Uses multiple propulsion energy sources, this means the electric motor and ICE propels the vehicle.

Series-parallel Hybrid

These vehicles can operate using the electric motor alone or with assist of the ICE, they combine both functions of series and parallel design.

5.1.2 Advantages and Disadvantages

Here are few of the top advantages of having a hybrid vehicles :

1. **Environmentally Friendly:** One of the biggest advantage of hybrid vehicle over gasoline powered car is that it runs cleaner and has better gas mileage which makes it environmentally friendly. A hybrid vehicle runs on twin powered engine (gasoline engine and electric motor) that cuts fuel consumption and conserves energy.
2. **Financial Benefits:** Hybrid cars are supported by many credits and incentives that help to make them affordable. Lower annual tax bills and exemption from congestion charges comes in the form of less amount of money spent on the fuel.
3. **Less Dependence on Fossil Fuels:** A Hybrid vehicles are much cleaner and requires less fuel to run which means less emissions and less dependence on fossil fuels. This in turn also helps to reduce the price of oil in domestic market.
4. **Regenerative Braking System:** Each time you apply brake while driving a hybrid vehicle helps you to recharge your battery a little. An internal mechanism kicks in that captures the energy released and uses it to charge the battery which in turn eliminates the amount of time and need for stopping to recharge the battery periodically.
5. **Built From Light Materials:** Hybrid vehicles are made up of lighter materials which means less energy is required to run. The engine is also smaller and lighter which also saves much energy.
6. **Higher Resale Value:** With continuous increase in price of gasoline, more and more people are turning towards hybrid cars. The result is that these green vehicles have started commanding higher than average resale values. So, in case you are not satisfied with your vehicle, you can always sell it at a premium price to buyers looking for it.

There disadvantages to owning a hybrid vehicles, but they are probably not what you think. Contrary to popular myth, hybrid vehicles have just as much power as regular vehicles and have no issue with mountain driving or towing. The disadvantages will depend on the type of hybrid fuel that your vehicles uses.

Here are few of the disadvantages of a hybrid vehicles:

1. **Less Power:** Hybrid vehicles are twin powered engine. The gasoline engine which is primary source of power is much smaller as compared to what you get in single engine powered car and electric motor is low power. The combined power of both is often less than that of gas powered engine. It is therefore suited for city driving and not for speed and acceleration.
2. **Can be Expensive:** The biggest drawback of having a hybrid vehicles is that it can burn a hole in your pocket. Hybrid cars are comparatively expensive than a regular petrol car and can cost \$5000 to \$10000 more than a standard version. However, that extra amount can be offset with lower running cost and tax exemptions.
3. **Poorer Handling:** A hybrid vehicles houses an gasoline powered engine, a lighter electric engine and a pack of powerful batteries. This adds weight and eats up the extra space in the car. Extra weight results in fuel inefficiency and manufacturers cut down weight which has resulted in motor and battery downsizing and less support in the suspension and body.
4. **Higher Maintenance Costs:** The presence of dual engine, continuous improvement in technology, and higher maintenance cost can make it difficult for mechanics to repair the car. It is also difficult to find a mechanic with such an expertise.
5. **Presence of High Voltage in Batteries:** In case of an accident, the high voltage present inside the batteries can prove lethal for you. There is a high chance of you getting electrocuted in such cases which can also make the task difficult for rescuers to get other passengers and driver out of the vehicles.

5.2 Smart Grid Systems

A smart grid is an electricity distribution network that can monitor electricity flowing within itself and, based on this self awareness, adjust to changing conditions. It does this by automatically reconfiguring the network and/or exerting a level of control over connected demand and generation.

A Smart Grid is a modern electricity system. It uses sensors, monitoring, communications, automation, and computers to improve the flexibility, security, reliability, efficiency, and safety of the electricity system.

Smart Grid generally refers to a class of technology people are using to bring utility electricity delivery systems into the 21st century, using computer-based remote control and automation.

These systems are made possible by two way communication technology and computer processing that has been used for decades in other industries. They are beginning to be used on electricity networks, from the power plants and wind farms all the way to the consumers of electricity in homes and businesses. They offer many benefits to utilities and consumers mostly seen in big improvements in energy efficiency on the electricity grid and in the energy users homes and offices.

The present revolution in communication systems and internet offers the possibility of much greater monitoring and control throughout the power system and hence more effective, flexible and lower cost operation. Smart Grid is an opportunity to use new ICTs (Information and Communication Technologies) to revolutionise the electrical power system.

It enables demand response and demand side management through the integration of smart meters, smart appliances and consumer loads, micro-generation, and electricity storage including (electric vehicles) and by providing customers with information related to energy use and prices. Customers will be provided with information and incentives to modify their consumption pattern to overcome some of the constraints in the power system

It accommodates and facilitates all renewable energy sources, distributed generation, residential micro-generation, and storage options, thus reducing the environmental impact.

It assures and improves reliability and the security of supply by being resilient to disturbances, attacks and natural disasters, anticipating and responding to system disturbances (predictive maintenance and self-healing), and strengthening the security of supply through enhanced transfer capabilities.

It maintains the power quality of the electricity supply to cater for sensitive equipment that increases with the digital economy. It opens access to the markets through increased transmission paths, aggregated supply and demand response initiatives and ancillary service provisions.



Figure 5.2.1: Smart grid.

5.3 Batteries

An electric battery is a device consisting of one or more electrochemical cells that convert stored chemical energy into electrical energy. Each cell contains a positive terminal, or cathode, and a negative terminal, or anode. Electrolytes allow ions to move between the electrodes and terminals, which allows current to flow out of the battery to perform work.

Primary (single-use or "disposable") batteries are used once and discarded; the electrode materials are irreversibly changed during discharge. Common examples are the alkaline battery used for flashlights and a multitude of portable devices. *Secondary (rechargeable batteries)* can be discharged and recharged multiple times; the original composition of the electrodes can be restored by reverse current.

Batteries have much lower specific energy (energy per unit mass) than common fuels such as gasoline. This is somewhat offset by the higher efficiency of electric motors in producing mechanical work, compared to combustion engines.

5.3.1 Principle of Operation

Batteries convert chemical energy directly to electrical energy. A battery consists of some number of voltaic cells. Each cell consists of two half-cells connected in series by a conductive electrolyte containing anions and cations. One half-cell includes electrolyte and the negative electrode, the electrode to which

anions (negatively charged ions) migrate; the other half-cell includes electrolyte and the positive electrode to which cations (positively charged ions) migrate.

Redox reactions power the battery. Cations are reduced (electrons are added) at the cathode during charging, while anions are oxidized (electrons are removed) at the anode during discharge. The electrodes do not touch each other, but are electrically connected by the electrolyte. Some cells use different electrolytes for each half-cell. A separator allows ions to flow between half-cells, but prevents mixing of the electrolytes.

The voltage developed across a cell's terminals depends on the energy release of the chemical reactions of its electrodes and electrolyte. If a charger cannot detect when the battery is fully charged then overcharging is likely, damaging it.

Disposable batteries typically lose 8 to 20 percent of their original charge per year when stored at room temperature (2030°C). This is known as the "self-discharge" rate.

Battery life can be extended by storing the batteries at a low temperature, as in a refrigerator or freezer, which slows the side reactions. Such storage can extend the life of alkaline batteries by about 5%; rechargeable batteries can hold their charge much longer, depending upon type.

5.3.2 C Rate

The C-rate is a measure of the rate at which a battery is being discharged. It is defined as the discharge current divided by the theoretical current draw under which the battery would deliver its nominal rated capacity in one hour. A 1C discharge rate would deliver the battery's rated capacity in 1 hour. A 2C discharge rate means it will discharge twice as fast (30 minutes). A 1C discharge rate on a 1.6 Ah battery means a discharge current of 1.6 A. A 2C rate would mean a discharge current of 3.2 A.

5.3.3 Lead Acid Batteries

They are oldest types of batteries, invented in 1859. It consists of lead plates of lead and lead oxide in presence of electrolyte (Approx. 35% sulfuric acid and 65% water). The cathode is made of metallic lead, and the anode of lead dioxide. Each lead-acid "cell" produces 2.14 volts. As the battery discharges, the electrolyte reacts with the plates, changing their surface to lead sulphate.



The lead sulphate product clings to the electrodes, so applied external voltage can reverse the reaction. When the battery is recharged, the lead sulphate reforms back into lead and lead oxide, and the specific gravity of the electrolyte is restored. Over time, the lead sulphate converts to a crystalline form that no longer dissolves on recharging. This process is accelerated if the battery is left in a discharged condition. Sulphation can be avoided if the battery is fully recharged immediately after a discharge cycle. Excessive charging electrolyses some of the water, producing hydrogen and oxygen (called "gassing") which mixture is highly explosive.

5.3.4 Types

1. **Flooded (Wet Cells):** Electrolyte is a liquid, battery is usually not sealed and not spill-proof and usually vent hydrogen gas during charging.
2. **Valve-Regulated Lead-Acid (VRLA):** They are of following types:
 - (a) **Gelled Electrolyte (Gel Cell):** Electrolyte is immobilized by a thickening agent.
 - (b) **Absorbed Glass Mat (AGM):** Electrolyte is absorbed in separators of matted glass fibers.

VRLA batteries are hermetically sealed and designed to produce little or no hydrogen gas during charging.

5.3.5 Battery Service Types

The three service types are Starting, Deep Cycle, and Marine:

1. **Starting:** Sometimes called SLI, for starting, lighting, ignition. They are typically available for automobile battery and are designed to produce very large starting current for a very short time. Such battery may last for thousands of cycles in normal starting use (2% - 5% discharge). Automotive batteries will generally fail after 30 - 150 deep cycles. The plates are composed of a lead "sponge" and they have very large surface area, but is quickly consumed if the battery is deep-cycled.
2. **Deep Cycle:** They are designed to be discharged as much as 80% of full capacity many times. They have maximum life if average discharge is kept at about 50%. The plates are usually solid lead, not sponge and have less surface area, hence less "instant power like starting batteries provide. It will not hurt a deep cycle battery to be used as a starting battery, but cannot supply as much cranking amps.
3. **Marine:** They are hybrid type batteries and they have characteristics between starting and deep-cycle batteries.

5.3.6 Nickel Batteries

Technical Summary

There are a number of Nickel based batteries currently available or under development, including Nickel-Cadmium (Ni-Cd), Nickel-Metal Hydride (Ni-MH), Nickel-Zinc (Ni-Zn) and Sodium-Nickel Chloride (Na-NiCl₂). Ni-Cd and Ni-MH are the most developed of the Ni batteries.

Energy Density and Discharge Time

These various Ni battery types cover the energy density range 20 - 120 Wh/kg (Dahlen, 2003). The lifetime of batteries is determined by the number of charge/discharge cycles that they can perform. Ni-Cd and Ni-MH batteries perform among the highest number of deep cycles relative to other battery technologies, typically up to around 1500 deep cycles. Ni-Zn and Na - NiCl₂ have a shorter lifetime. Ni-Cd batteries also have a strong memory effect, where as in Ni-MH batteries the effect is much less significant.

Energy Efficiency

Ni-Cd and Ni-MH batteries are the most developed of the Nickel batteries. However, they also offer the lowest efficiency, discharging around 70 % of the energy used during charging, although Ni-Cd batteries have a lower self-discharge rate than Ni-MH. In comparison, NiZn batteries offer efficiencies of 80% and Na - NiCl₂ batteries have an efficiency of around 90%.

Development/Deployment status

Ni-Cd batteries have been produced since the early 20th century and formed the majority of the rechargeable battery market in consumer electronics by the 1990s. The first consumer Ni-MH batteries appeared in the 1980s and have replaced Ni-Cd in many rechargeable battery applications. Despite being used widely in electric vehicles, there are few examples of their application to electricity markets.

Applications

The Golden Valley Electric Association (GVEA) in Fairbanks, Alaska installed a large scale Ni-Cd Battery Energy Storage System (BESS) to provide 27 MW of electricity for a minimum of 15 minutes to stabilise the local power grid in the event of sudden loss of generation. The BESS was designed and built by Saft, an international battery manufacturer, and comprises 13,760 Saft SBH 920 high-performance rechargeable Ni-Cd cells arranged in four parallel strings. The system provides a nominal voltage of 5,000 V and a storage capacity of 3,680 Ah. At the time, the BESS was awarded the Guinness World Record for "the world's most powerful battery" by delivering 46 MW for 5 minutes.

Economics

Both Ni-Cd and Ni-MH batteries are expensive to manufacture relative to other battery technologies, possibly twice the cost of Lithium batteries and potentially four times the cost of lead acid batteries. The GVEA BESS discussed above was developed in 2005 at a cost of US\$ 30-million.

Environmental Impacts and Regulatory Issues

The most significant drawback of Ni-Cd batteries is the highly toxic cadmium used within them. Although this metal is highly recyclable it is exceedingly toxic. Most Nickel is recovered from end-of-life batteries since the metal is reasonably easy to retrieve from scrap and can be used in corrosion resistant alloys such as stainless steel. EU legislation is in part responsible for the supercedence of Ni-Cd batteries by Ni-MH batteries and represents a significant issue to any future development of Ni-Cd battery technologies.

5.3.7 Lithium Batteries

Technical summary

In common with other advanced battery systems, Lithium batteries are electrochemical cells. Lithium-Ion (Li-ion) and Lithium-Polymer (Lipol) types are both available.

Energy Density and Discharge Time

Li-ion and Li-pol batteries offer high charge densities of 100–150 Wh/kg (INVESTIRE, 2003). Nano composite electrode systems may offer even higher energy densities.

Energy Efficiency

Charge/discharge efficiencies of 90–100% are reported for Lithium batteries.

Development/Deployment status

Li-ion batteries have taken over 50% of the small portable market in the last few years, however there are some challenges for making large-scale Li-ion batteries. Under the EU 6th Framework Programme a consortium of European organisations is investigating advanced lithium energy storage systems based on the use of nano-powders and nano-composite electrodes/electrolytes. According to a 2004 report from the Taiwanese Industrial Technology and Research Institute (ITRI, 2004) their nano composite electrode technologies can provide energy densities of greater than 200 Wh/kg.

Economics

According to the Energy Storage Association (ESA, 2007) the main hurdle associated with mass energy storage systems using Li batteries is the high cost (above 420/kWh) due to special packaging and internal overcharge protection circuits. Several companies are working to reduce the manufacturing cost of Li-ion batteries to capture large energy markets (multi-kW, kWh sizes for residential and commercial markets). The automotive industry is one of the main drivers behind this development.

Environmental Impacts and Regulatory Issues

Li batteries have a limited environmental impact since the lithium oxides and salts can be recycled.

5.3.8 Lead-Acid Batteries

Technical summary

In common with other advanced battery systems, Lead-Acid batteries are electrochemical cells, in this case based upon chemical reactions involving lead and sulphuric acid. Lead-Acid is one of the oldest and most developed battery technologies.

Energy Density and Discharge Time

Because of the high density of the materials used in these batteries, the typical energy densities are lower than other batteries at 25–45 Wh/kg.

Energy Efficiency

Charge/discharge efficiencies for lead-acid batteries are 60–95% with self-discharge rates of 2 to 5% per month (Lailier, 2003).

Development/deployment status

In stationary storage applications, energy density is typically of less importance and lead acid battery energy storage systems have traditionally dominated this market, partly due to their low cost.

Economics

Lead acid batteries are low cost compared to other battery technologies, being as much as 8 times less expensive than Li batteries and up to 13 times less than Ni batteries. The cost in 1995 prices of the BEWAG and Vernon installations discussed above were 707 and 305\$/kWh respectively.

Environmental Impacts and Regulatory Issues

The lead used in these batteries is toxic and therefore must be recycled. In addition, the sulphuric acid typically used as the electrolyte is corrosive and when overcharged the battery generates hydrogen which presents an explosion risk. Under Directive 2006/66/EC, a minimum recycling rate of 65% by average weight of lead acid batteries must be reached in EU Member States by September 2011.

5.3.9 Flow Batteries

Technical summary

Flow batteries store and release energy through a reversible electro-chemical reaction between two electrolytes. There are four types of flow battery currently being produced or in the late stages of development; zinc bromine, vanadium redox (VRB), polysulphide bromide and cerium zinc. The zinc-bromine system - developed by ZBB Energy Corp in the USA - represents a type of hybrid flow battery. A leading form of the vanadium redox flow battery is a system by VRB Power Systems Inc in Canada.

These systems feature the separation of chemical reactants from the electrochemical cells through which charging and discharging take place. The storage capacity is dependent upon the size of the electrolyte tanks whilst the power output is dependent upon the size of the fuel cell. The vanadium redox system has an advantage over the hybrid system as the discharge time at full power can be varied.

Energy Density and Discharge Time

VRBs can be fully discharged without reducing life expectancy. A VRB in Sapporo, Japan has undergone around 14,000 discharge cycles, this gives it a competitive advantage over many other storage technologies.

Energy Efficiency

These systems have quoted efficiencies varying from 70% (cerium zinc) to 85%.

Development/Deployment status

The VRB system is currently being deployed at a number of wind farms around the world. A case study of Sorne Wind Farm in Ireland is given below. The ZBB system has been undergoing testing at the DUIT facility in the US at a 500 kWh scale, with plans to link four to make a 2 MWh battery. A report on US energy storage (UK DTI, 2006) commented that the ZBB system was the noisiest system observed and the presence of multiple pumping circuits also indicates that regular maintenance activity will be required. Whilst these technology examples are in the early stages of development it would appear that the Vanadium battery is currently the lead technology.

Economics

The overall cost of a 2MWh ZBB system would be in the region of 1.8 million. The cost of the VRB system illustrated in Case Study 1 was just over 6 million for a 2MW, 12 MWh system.

Environmental Impacts and Regulatory Issues

The potential size and scale of these systems are likely to determine the extent to which environmental impacts are significant. Significant quantities of space may be required for holding tanks containing the electrolytes and although these substances may not be specifically toxic this obviously requires care at the design stage. A major advantage of the technology is the ability of the technology to perform discharge cycles indefinitely so there are no significant waste products associated with operation.

5.3.10 Metal-Air Batteries

Technical summary

In common with other advanced battery systems, metal-air batteries are electrochemical cells. Metal-air batteries are the most compact batteries available according to the Energy Storage Association (ESA, 2007).

Energy Density and Discharge Time

Energy densities for metal air batteries can be high covering the range 110 to 420 Wh/kg

Energy Efficiency

The most significant disadvantage of metal-air batteries is the inefficient electrical recharging leading to a typical charge/discharge efficiency of around 50%.

Development/Deployment status

Of all the metal-air systems developed to date the zinc-air battery is the most advanced despite the fact that other metal electrodes have a higher theoretical energy density. The deployment of metal-air batteries is limited to small-scale applications such as hearing aids or systems in which the fuel cells are mechanically refuelled. The electrical recharge-ability of these batteries needs to be improved to enable competition with other rechargeable battery technologies.

Economics

The capital costs of metal-air batteries are quoted as one of the least expensive (ESA, 2007) but this cost must be treated with caution since these batteries are very difficult and inefficient to re-charge.

Environmental Impacts and Regulatory Issues

Environmentally, metal-air batteries are relatively inert since no toxic materials are involved in their construction. In common with other battery types, metals such as zinc or aluminium used within the battery should be recycled.

5.3.11 Sodium-Sulphur Batteries(NaS)

Technical summary

In common with other advanced battery systems, Sodium-Sulphur (NaS) batteries are electrochemical cells. NaS batteries are the most developed type of high temperature battery. A NaS battery consists of liquid (molten) sulphur at the positive electrode and liquid (molten) sodium at the negative electrode as active materials separated by a solid beta alumina ceramic electrolyte. The electrolyte allows only the positive sodium ions to pass through it and combine with the sulphur to form sodium poly-sulphides.

Energy Density and Discharge Time

NaS batteries have a relatively high energy density, within the range 150–240 Wh/kg (DTI, 2004). NaS has significant potential to become a cost-effective, modular, and portable bulk storage medium as it is specifically designed for long discharge cycles (8 hours), but has the capacity to discharge very rapidly and at multiples of rated power

Energy Efficiency

These batteries have an estimated lifetime of 15 years with a cycle life of 2500–4500 and charge/discharge efficiencies up to 90%.

Development/deployment status

Research and development into NaS batteries has been pioneered in Japan since 1983 by the Tokyo Electric Power Corporation (TEPCO) and NGK. As of 2004 there were 59 NaS energy storage systems with capacities rated greater than 500 kW (Mears, 2005). In total more than 100 MW of NaS energy storage capacity has been installed, mostly in Japan where this energy storage technology is a commercial reality.

Economics

AEP anticipate the combined cost for the three installations ordered in 2007, including site preparation, equipment and control systems, will be around \$27 million (18.9 million). A study of the 2002 NaS demonstration project carried out for the US Department of Energy energy storage program calculated a potential 9.8% rate of return on investment in the system and suggested the present value of power quality benefits were over three times the present value of peak shaving benefits (Norris B et al., 2007).

Environmental Impacts and Regulatory Issues

There are limited environmental concerns associated with NaS batteries, since the materials used in their construction are relatively environmentally inert. There is a small risk associated with the high temperature at which the battery must be operated in order to maintain the sulphur in its molten form.

5.4 Super Capacitors

A supercapacitor (SC), sometimes ultracapacitor, formerly electric double-layer capacitor (EDLC) is a high-capacity electrochemical capacitor with capacitance values up to 10,000 farads at 1.2 volt that bridge the gap between electrolytic capacitors and rechargeable batteries. They typically store 10 to 100 times more energy per unit volume or mass than electrolytic capacitors, can accept and deliver charge much faster than batteries, and tolerate many more charge and discharge cycles than rechargeable batteries. They are however 10 times larger than conventional batteries for a given charge.

The amount of energy a capacitor is capable of storing can be increased by either increasing the capacitance or the voltage stored on the capacitor. The stored voltage is limited by the voltage withstand strength of the dielectric. As with batteries, the turn around efficiency when charging/discharging capacitors is also an important consideration, as is response time. The effective series resistance of the capacitor has a significant impact on both. The total voltage change when charging or discharging capacitors is shown in equation.

$$q = CV \quad (5.2)$$

$$C = \frac{A\epsilon}{d} \quad (5.3)$$

$$E = \frac{1}{2}CV^2 \quad (5.4)$$

$$dV = i \frac{dt}{C} + iR \quad (5.5)$$

The supercapacitor (rated in Farads), also known as ultracapacitor differs from a regular capacitor in that it has a very high capacitance. A capacitor stores energy by means of a static charge as opposed to an electrochemical reaction. Applying a voltage differential on the positive and negative plates charges the capacitor.

The supercapacitor is ideal for energy storage that undergoes frequent charge and discharge cycles at high current and short duration. Supercapacitors or double-layer capacitors (DLCs) as they are also known, contain a significantly enlarged electrode surface area compared to conventional capacitors. Supercapacitors are capable of very fast charging and discharging times, and are able to go through many cycles without degradation. Typical efficiencies for supercapacitors are high (85–98%) making them an attractive storage technology for many applications, however currently these are mostly small-scale.